



ADVANCED
BOLTING
TECHNOLOGY



PNEUMATIC



ELECTRONIC



BATTERY



ELECTRIC



SMART SOCKET

WWW.RADTORQUE.COM

B-RAD XTREME USER MANUAL

RAD TORQUE SYSTEMS

PNEUMATIC SERIES



- **PATENTED PLANETARY GEAR REDUCTION**
Delivers one of the highest power-to-weight ratios of any pneumatic controlled bolting system
- **SMOOTH CONTINUOUS FLOW OF CONTROLLED TORQUE**
Eliminates destructive hammering
- **LIGHTWEIGHT ERGONOMIC PISTOL GRIP DESIGN**
Reduces operator strain and injury; resulting in increased productivity
- **UNMATCHED RELIABILITY AND QUALITY**
Delivered by one of the most advanced engineered gear boxes on the market

ELECTRONIC SERIES E-RAD



- **PUSH-BUTTON SELECT TORQUE**
Fast and convenient error-free digital single increment torque settings
- **DIGITAL TORQUE CONSOLE DISPLAY**
Maximum accuracy by seeing the set torque value and the actual delivered torque value
- **LIGHTWEIGHT AND ERGONOMIC PISTOL GRIP DESIGN**
Advanced low-profile handle to reduce operator fatigue and increase productivity
- **EXTREMELY LOW NOISE LEVEL ONLY 75DB**
World's quietest extreme torque gun, ideal for sensitive environments and standards
- **LED GREEN (PASS) OR RED (FAIL) INDICATOR LIGHTS**
Unmistakable visual signal indicates status of torque procedure for maximum accuracy and speed

BATTERY SERIES B-RAD



- **QUICK ADJUST TORQUE SETTINGS**
Fast and accurate "dial a torque" for maximum versatility and efficiency
- **SOFT-START VARY SPEED TRIGGER**
Allows operator to safely and quickly set reaction arm before full torque is applied
- **EQUAL POWER IN FORWARD AND REVERSE**
Convenience and cost effective use of same tool for break away and final torque
- **IMAGINE THE FREEDOM - NO AIR LINES, NO POWER CORDS!**
The lightweight design of the B-SERIES makes it ideal for any application, especially where compressed air and electricity are not readily available.
- **ADVANCED GEARBOX DESIGN**
PATENTED planetary gear reduction drive system delivering one of the highest power-to-weight ratios of any controlled bolting system

ELECTRIC SERIES V-RAD



- **QUICK ADJUST TORQUE SETTINGS**
Fast and accurate "dial a torque" for maximum versatility and efficiency
- **SOFT-START VARY SPEED TRIGGER**
Allows operator to safely and quickly set reaction arm before full torque is applied
- **EQUAL POWER IN FORWARD AND REVERSE**
Convenience and cost effective use of same tool for break away and final torque
- **ADVANCED ULTRA-DURABLE ELECTRIC MOTOR DESIGN**
Extreme duty designed to reduce maintenance cost and increase reliability
- **ADVANCED GEARBOX DESIGN**
Patented planetary gear reduction drive system delivering one of the highest power-to-weight ratios of any controlled bolting system

SMART SOCKET™ SERIES



- **MEASURE AND DISPLAY PEAK TORQUE**
Transducer technology combined with a custom socket measures the actual torque applied to the bolt during a torque cycle.
- **PASS OR FAIL INDICATION**
Unmistakable digital signal indicates peak torque achieved for maximum accuracy
- **BLUETOOTH® TECHNOLOGY**
View and download logs onto your smartphone or tablet
- **IDEAL ON SITE CALIBRATION TOOLS**
Comparable in size to a standard socket, it's the perfect tool for inspecting bolted joints and can function as a master calibrator for your torque tools

NOTICE:

This manual applies to the following hardware and firmware release:
B-RAD_X_V07.0F.20_07.11.21
 Use with any other firmware version may produce unexpected results.

TABLE OF CONTENTS

Manual Revision History3

Important Safety Notice.....4

General Power Tool Safety Warnings4

Battery Pack Safety Warnings6

Symbol Identification 7

1.0 General Information8

1.1 System Components 8

1.2 Specifications 9

 1.2.1 Tool Model Specifications 9

 1.2.2 Battery Specifications 10

 1.2.3 Environmental Specifications 11

 1.2.4 Cycle of Operation 11

2.0 Tool System..... 12

2.1 Tool Handle..... 12

2.2 Tool Interface 12

 2.2.1 Keypad 13

 2.2.2 Main Screen..... 13

 2.2.3 Audible Status Indicator 13

2.3 RAD HD Battery Pack..... 14

 2.3.1 Insert/Remove the RAD HD Battery Pack 14

 2.3.2 Check RAD HD Battery Charge 15

2.4 RAD Battery Charger 15

 2.4.1 Charging the RAD HD Battery Pack..... 16

 2.4.2 Charging Errors 16

3.0 Interface and Settings..... 17

3.1 Access Levels 17

 3.1.1 Unlocking Access Levels..... 18

3.2 Using the Interface..... 18

 3.2.1 Changing the Target Torque..... 18

 3.2.2 Changing the Target Angle 19

 3.2.3 Toggling Forward and Reverse 19

 3.2.4 Menu Navigation 19

3.3 Basic Level Menu Options 20

 3.3.1 Information Menu 20

 3.3.2 Change Torque Units 20

3.4 Advanced Level Menu Options 20

 3.4.1 Configuration Menu 20

 3.4.2 LED Display Brightness 20

 3.4.3 The 2-Hand Safety Setting 21

 3.4.4 Angle Enable/Disable Setting 21

 3.4.5 Back-Off Setting..... 22

 3.4.6 Audio Indication Setting 22

 3.4.7 Statistics Menu 22

3.5 Display Mode – Torque vs. Table 23



3.6 Menu Tree - Overview	24
4.0 General Operating Instructions	26
4.1 Reaction Arm	26
Installing the Reaction Arm.....	26
Reaction Points.....	27
Personal Safety.....	27
Reaction Arm Height.....	28
Reaction Arm Foot.....	28
Reaction Point.....	28
4.2 Collet Output Carrier Tool	29
4.3 Torque Operation	30
4.4 Torque and Angle Operation	30
5.0 Calibration	31
5.1 Calibration Menu Navigation	31
5.1.1 Calibration Recovery.....	31
5.2 Table of Calibration Menus	32
5.3 Calibration Procedure	32
6.0 Troubleshooting	34
6.1 Faults and Errors	34
6.1.1 Errors.....	34
6.1.2 Operating Errors.....	35
6.1.3 Faults.....	35
7.0 Contact Us	40

MANUAL REVISION HISTORY

V2023.05.15

- Updated for Release

V2023.05.16

- Fixed PDF

V2023.06.01

- Updated Section 5 to include battery recommendation for calibration
- Updated Section 6.1.1 to include Calibration lockout message description

V2024.12.03

- Updated: 7.0 Contact Us – Bluetooth® trademark statement

V2025.01.17

- Updated Section 1.2.1 Tool Model Specifications to include B-RAD X 3000 model
- Updated Section 1.2.2 Battery Specifications battery recommendation statement
- Added Section 3.2.2 Changing the Target Angle
- Added Section 3.4.5 Angle Enable/Disable Setting
- Added Section 4.3 Torque and Angle Operation
- Updated Section 3.6 Menu Tree – Overview
- Updated Section 6.1.2 Faults table 6.1.2-1

V2025.12.11

- Reformatting of manual
- Updated General Safety Warnings
- Section 3.1: Update table
- Section 3.4.2: Change Torque Units moved to Basic Functions as Section 3.3.2
- Section 3.6: Updated photos in the menu tree
- Section 4.0: Updated images
- Added Section 6.1.2: Operating Errors

V2026.01.23

- Section 1.2.1: Updated table and added note
- Added Section 4.2: Collet Output Carrier Tool
- Section 4.4: Caution added

V2026.05.11

- Updated Battery Pack Safety Warnings
- Added Section: Symbol Identification
- Section 1.2.1: Updated table

B-RAD X Tool System – Original Instructions

IMPORTANT SAFETY NOTICE



WARNING!

READ ALL SAFETY WARNINGS, INSTRUCTIONS, ILLUSTRATIONS, AND SPECIFICATIONS PROVIDED WITH THIS POWER TOOL. FAILURE TO FOLLOW ALL INSTRUCTIONS LISTED BELOW MAY RESULT IN ELECTRIC SHOCK, FIRE AND/OR SERIOUS INJURY.

SAVE ALL WARNINGS AND INSTRUCTIONS FOR FUTURE REFERENCE.

GENERAL POWER TOOL SAFETY WARNINGS

The term “power tool” in the warnings refers to your battery-operated (cordless) power tool.

The B-RAD X Tool System should be inspected before each use.

1. Work Area Safety

- a. **Keep work area clean and well lit.** Cluttered and dark areas invite accidents.
- b. **Do not operate power tools in explosive atmospheres, such as environments with the presence of flammable liquids, gases, or dust.** Power tools create sparks which may ignite the dust or fumes.
- c. **Keep children and bystanders away while operating the power tool.** Distractions can cause you to lose control.

2. Electrical Safety

- a. **Power tool plugs must match the outlet. Never modify the plug in any way. Do not use any adapter plugs with earthed (grounded) power tools.** Unmodified plugs and matching outlets will reduce the risk of electric shock.
- b. **Avoid body contact with earthed (grounded) surfaces such as pipes, radiators, ranges, or refrigerators.** There is an increased risk of electric shock if your body is earthed (grounded).
- c. **Do not expose power tools to rain or wet conditions.** Water entering a power tool will increase the risk of electric shock.
- d. **Do not abuse the cord. Never use the cord to carry, pull, or unplug the power tool. Keep cord away from heat, oil, sharp edges, and moving parts.** Damaged or entangled cords increase the risk of electric shock.
- e. **When operating a power tool outdoors, use an extension cord suitable for outdoor use.** Use of a cord suitable for outdoor use reduces the risk of electric shock.
- f. **If operating a power tool in a damp location is unavoidable, use a Ground Fault Circuit Interrupter (GFCI) protected supply.** Use of a GFCI reduces the risk of electric shock.

3. Personal Safety

- a. **Stay alert, watch what you are doing, and use common sense when operating a power tool. Do not use a power tool while you are tired or under the influence of drugs, alcohol, or medication.** A moment of inattention while operating power tools may result in serious personal injury.
- b. **Use personal protective equipment and always wear eye protection.** Protective equipment such as a dust mask, non-skid safety shoes, hard hat, and hearing protection used in appropriate conditions will reduce personal injuries.
- c. **Prevent unintentional starting by ensuring the switch is in the off position before connecting to a power source and/or battery pack, picking up, or carrying the tool.** Carrying power tools with your finger on the switch or energizing power tools that have the switch on invites accidents.
- d. **Remove any adjusting key or wrench before turning the power tool on.** A wrench or a key left attached to a rotating part of the power tool may result in personal injury.
- e. **Do not overreach. Always keep proper footing and balance.** This enables better control of the power tool in unexpected situations.

- f. **Dress properly. Do not wear loose clothing or jewellery.** Keep your hair, clothing, and gloves away from moving parts.
- g. **If devices are provided for the connection of dust extraction and collection facilities, ensure these are connected and properly used.** Use of dust collection can reduce dust-related hazards.
- h. **Do not let familiarity gained from frequent use of tools allow you to become complacent and ignore tool safety principles.** A careless action can cause severe injury within a fraction of a second.

4. Power Tool Use and Care

- a. **Do not force the power tool.** Use the correct power tool for your application.
- b. **Do not use the power tool if the switch does not turn it on and off.** A power tool that cannot be controlled with the switch is dangerous and must be repaired.
- c. **Disconnect the power source and/or the battery pack from the power tool before making any adjustments, changing accessories, or storing power tools.** Such preventive measures reduce the risk of starting the power tool accidentally.
- d. **Store idle power tools out of the reach of children and do not allow persons unfamiliar with the power tool or these instructions to operate the power tool.** Power tools are dangerous in the hands of untrained users.
- e. **Power tools must be properly maintained. Check for misalignment or binding of moving parts, breakage of parts, and any other condition that may affect the power tool's operation.** If damaged, have the power tool repaired before use. Many accidents are caused by poorly maintained power tools.
- f. **Use the power tool and accessories in accordance with these instructions, considering the working conditions and the work to be performed.** Use of the power tool for operations different from those intended could result in a hazardous situation.
- g. **Keep handles and grasping surfaces dry, clean, and free from oil and grease.** Slippery handles and grasping surfaces do not allow for safe handling and control of the tool in unexpected situations.

5. Battery tool use and care

- a. **Recharge only with the charger specified by the manufacturer.** A charger that is suitable for one type of battery pack may create a risk of fire when used with another battery pack.
- b. **Use power tools only with specifically designated battery packs.** Use of any other battery packs may create a risk of injury and fire.
- c. **When battery pack is not in use, keep it away from other metal objects, like paper clips, coins, keys, nails, screws, or other small metal objects that can make a connection from one terminal to another.** Shorting the battery terminals together may cause burns or a fire.
- d. **Under abusive conditions, liquid may be ejected from the battery; avoid contact. If contact accidentally occurs, flush with water. If liquid contacts eyes, additionally seek medical help.** Liquid ejected from the battery may cause irritation or burns.
- e. **Do not use a battery pack or tool that is damaged or modified.** Damaged or modified batteries may show unpredictable behaviour resulting in fire, explosion, or risk of injury.
- f. **Do not expose a battery pack or tool to fire or excessive temperature.** Exposure to fire or temperature above 130 °C (265 °F) may cause explosion.
- g. **Follow all charging instructions and do not charge the battery pack or tool outside the temperature range specified in the instructions.** Charging improperly or at temperatures outside the specified range may damage the battery and increase the risk of fire.

6. Service





- a. **Have your power tool serviced by a qualified repair person using only identical replacement parts.** This will ensure that the safety of the power tool is maintained.
- b. **Never service damaged battery packs.** Service of battery packs should only be performed by the manufacturer or authorized service providers.

BATTERY PACK SAFETY WARNINGS

- a. **Only use the RAD HD battery pack with the B-RAD X Tool System.** The use of other batteries with the B-RAD X Tool System will cause damage to the tool.
- b. **The RAD HD battery pack should only be charged on the RAD HD battery charger.** If an incompatible charger is used, damage to the RAD HD battery will occur.
- c. **Follow all charging instructions and do not charge the battery pack or tool outside the temperature range specified in the instructions.** Charging improperly or at temperatures outside the specified range may damage the battery and increase the risk of fire.
- d. **Keep the RAD HD battery pack away from any metal objects.** If the battery terminals are connected by a metal object, the battery will short and will cause damage to the battery and injury to the operator. Even discharged battery packs can cause short circuits because they have a residual charge to protect against a deep discharge. To avoid accidental and unwanted short circuits, insulate the battery contacts with a protective cap or adhesive tape when not in use.
- e. **Do not expose the RAD HD battery pack to wet conditions.** Protect battery packs against moisture and do not immerse in liquids. This will cause damage to the RAD HD battery and increase the risk of electric shock. Contact with liquids can cause damage, which sometimes leads to heat generation, smoke, ignition or explosion of the battery pack sometimes hours or days after exposure.
- f. **Do not use faulty, damaged or deformed RAD HD batteries. Do not attempt to open the RAD HD battery. Do not short circuit the RAD HD battery.** Battery packs that show abnormal properties such as abnormal heating or poor power output, show signs of odor, heat, discoloration or thermal deformation should not be used. The use of defective or faulty battery packs can cause fire and explosion. Failure to comply will cause damage to the RAD HD battery and injury to the operator.
- g. **Do not expose battery packs or tools to fire or excessive heat.** Fire or temperatures above 130 ° C (265 °F) may cause the battery pack to ignite or explode. Failure to comply will cause damage to the RAD HD battery and injury to the operator.
- h. **If liquid is ejected from the RAD HD battery, avoid contact. If contact with skin occurs, immediately flush with water. If contact with eyes occurs, immediately flush with water and seek medical aid.** Liquid from the RAD HD battery may cause irritation and/or burns.
- i. **RAD HD battery packs cannot be disposed of with regular waste.** Dispose of RAD HD batteries according to local regulations or return RAD HD batteries to your RAD distributor.

Symbol Identification

These are symbols that can be found on the tool or in this manual and information about them.

	<p>Refer to instruction manual/booklet. This is used to signify that the instruction manual/booklet must be read.</p>
	<p>Do not expose battery packs to fire.</p>
	<p>Do not throw battery packs into the garbage.</p>
	<p>Protect battery packs from water and moisture.</p>

1.0 GENERAL INFORMATION

1.1 System Components

The B-RAD X Tool System is shipped in a custom foam-lined storage case with the following parts:

- B-RAD X tool (Figure 1.1-1)
- Two RAD HD battery packs (Figure 1.1-2)
- RAD battery charger (Figure 1.1-3)
- Standard reaction arm and snap ring (Figure 1.1-4)
- Calibration certificate
- User manual



Figure 1.1-1: B-RAD X



Figure 1.1-2: RAD HD Battery Pack



Figure 1.1-3: RAD Battery Charger



Figure 1.1-4: Standard Reaction Arm

1.2 Specifications

1.2.1 Tool Model Specifications

The following table outlines the torque ranges, speed, and weight of the B-RAD X models.

Tool Model	Torque Range (Imperial)	Torque Range (Metric)	Speed	Weight (incl. battery)
B-RAD X 350 / 500-M	35 – 350 ft·lb	47 – 475 N·m	41.5 RPM	11.1 lb / 5 kg
B-RAD X Offset 350 / 500-M	35 – 350 ft·lb	47 – 475 N·m	41.5 RPM	12 lb / 5.5 kg
B-RAD X 500 / 700-M	50 – 500 ft·lb	68 – 678 N·m	27.6 RPM	11.1 lb / 5 kg
B-RAD X Offset 500 / 700-M	50 – 500 ft·lb	68 – 678 N·m	27.6 RPM	12 lb / 5.5 kg
B-RAD X 1000 / 1400-M	100 – 1000 ft·lb	136 – 1356 N·m	14.5 RPM	12.3 lb / 5.6 kg
B-RAD X Offset 1000 / 1400-M	100 – 1000 ft·lb	136 – 1356 N·m	14.5 RPM	13.3 lb / 6 kg
B-RAD X 1500 / 2000-M	150 – 1500 ft·lb	203 – 2034 N·m	9.3 RPM	13.1 lb / 5.9 kg
B-RAD X Offset 1500 / 2000-M	150 – 1500 ft·lb	203 – 2034 N·m	9.3 RPM	13.9 lb / 6.3 kg
B-RAD X 3000* / 4000-M	250 – 3000 ft·lb	339 – 4000 N·m	3.9 RPM	17.4 lb / 7.9 kg
B-RAD X HD 3000 / 4000-M	250 – 3000 ft·lb	339 – 4000 N·m	3.9 RPM	17.5 lb / 8 kg
B-RAD X Offset 3000 / 4000-M	250 – 3000 ft·lb	339 – 4000 N·m	3.9 RPM	18.6 lb / 8.5 kg
B-RAD X 5000* / 7000-M	500 – 5000 ft·lb	700 – 7000 N·m	2.4 RPM	23.2 lb / 10.5 kg
B-RAD X Offset 5000 / 7000-M	500 – 5000 ft·lb	700 – 7000 N·m	2.4 RPM	24.6 lb / 11.2 kg
B-RAD X 8000 / 10K-M	740 – 8000 ft·lb	1000 – 10850 N·m	1.7 RPM	30.3 lb / 13.8 kg
B-RAD X Offset 8000 / 10K-M	740 – 8000 ft·lb	1000 – 10850 N·m	1.7 RPM	32.1 lb / 14.6 kg
B-RAD X 11K / 15K-M	1100 – 11000 ft·lb	1500 – 15000 N·m	1.2 RPM	42.4 lb / 19.3 kg
B-RAD X Offset 11K / 15K-M	1100 – 11000 ft·lb	1500 – 15000 N·m	1.2 RPM	43.7 lb / 19.9 kg

Table 1.2.1-1: Tool Model Torque Ranges and Weights

Note: Tool models marked with an * are available with output carrier variants. For information on using the collet tool variation see Section 4.2 Collet Output Carrier Tool.

1.2.2 Battery Specifications

Ensure that all battery specifications are followed when using the B-RAD X Tool System.

Use only RAD HD series 18V batteries.

Battery	
Voltage	18VDC Nominal 13.5 - 43V Maximum
Current	120 ADC Peak
Capacity	5.5 Ah or 8 Ah batteries
State of Battery	LED-Display
Charge	LED1>20%, LED2>40%, LED3>60%, LED4>80%
Battery Empty	LED1<20%, 3 times flashing
Electronic Awake	LED4, short flashing each 15s
Over Voltage, Wire Break	LED1, LED2, and LED4, short flashing each 15s
Weight	5.5 Ah - 845g / 1.9 lb 8 Ah - 977g / 2.2 lb
Operating Temperature	-20°C - 50°C / -4°F - 122°F
Storage Temperature	-20°C - 60°C / -4°F - 140°F
Vibrations and Shock	< 5G, (x-, y-, z- axis)
Humidity	< 90% (non-condensing)
Dust/ Moisture Protection	IP20
Charger Voltage	
Input	115 or 230 VAC
Output	12 - 18 VDC
Charger Output Current	2.5 A
Operating Temperature	0°C - 40°C / 32°F - 104°F
Storage Temperature	-40°C - 75°C / -40°F - 167°F
Charge Time	5.5 Ah < 110 minutes 8 Ah < 160 minutes

Table 1.2.2-1: Battery Specifications

Note: 5.2 Ah and 10 Ah batteries not recommended as performance will be reduced.

1.2.3 Environmental Specifications



CAUTION!

Only operate the B-RAD X Tool System if the following storage and operation conditions have been met.

It is recommended that the operator wears hearing protection.

WARNING!

The vibration emission during actual use of the power tool can differ from the declared total value depending on the ways in which the tool is used.

Identify safety measures to protect the operator that are based on an estimation of exposure in the actual conditions of use (taking account of all parts of the operating cycle such as the times when the tool is switched off and when it is running idle in addition to the trigger time).

	All Models	
	°C	°F
Ambient Operating Temperature Range	0 – 40	32 – 104
Storage Temperature Range	-20 – 70	-4 – 158
Required Operating Conditions	Non-explosive atmosphere, dry location	
Humidity	10% to 90% non-condensing	
Shock	10G according to DIN IEC 68-2-6/29	
Vibration Emission / Uncertainty = K	Does not exceed 2.5 m/s ² ; K = 1.5 m/s ²	
Noise Emissions		
A-weighted sound pressure level - LpA	Does not exceed 75dB(A)	
A-weighted sound power level - LWA / Uncertainty = K	86.0dB(A); K = 1.51dB	

Table 1.2.3-1: Environmental Specifications

Note: The declared vibration total value has been measured in accordance with a standard test method. It may be used for comparing one tool with another and may be used in a preliminary assessment of exposure.

1.2.4 Cycle of Operation

A cycle of operation or a tool cycle as used in this manual is defined as:

- 10 seconds on (forward or reverse)
- 10 seconds off

Note: the "on" here is defined as where torque is applied to the system.

Note: An actual torque cycle may vary from the general definition above.

2.0 TOOL SYSTEM

The following sections introduce the operation of the tool handle, reaction arm, led display interface, RAD HD battery pack, and RAD battery charger.

2.1 Tool Handle

The B-RAD X (Figure 2.1-1) is activated with a trigger switch. Torque values and tool information are displayed on 5-digit LED display. Four buttons are used to enter the desired torque setting and view the menus. The RAD HD battery pack is attached to the bottom of the tool handle.

1. Trigger switch – tool activation
2. LED display module with 4 buttons – refer to Section 2.2 LED Display Module
3. RAD HD battery pack – refer to Section 2.3 RAD HD Battery Pack
4. Battery release button and lock - refer to Section 2.3.1 Insert/Remove the RAD HD Battery Pack
5. Reaction arm
6. Fan filter
7. Hand guard
8. Hanger (not shown)
9. Snap ring (not shown)



Figure 2.1-1: B-RAD X Tool System

2.2 Tool Interface



CAUTION!

The display module may be damaged by mechanical shock, electrostatic discharge, excessive force, moisture, or extreme temperatures. Avoid such conditions and gently wipe clean or let dry before use.

To turn on the LED display, attach the RAD HD battery to the B-RAD X handle and press the trigger switch momentarily.

The LED display has a 5-digit display to show the torque values and menu options, LEDs for indicating both forward and reverse directional rotation, LEDs to indicate the type of units the tool is operating in, and 4 buttons that can be used to change settings and navigate menus.

The trigger is disabled when entering the menu system. Only certain sub menu systems will allow the tool to operate.

The entire tool will shut down after 10 minutes of inactivity. To turn the tool back on, press the trigger switch once and the system will restart.

2.2.1 Keypad

The keypad consists of 4 buttons that are located on either side of the LED display as shown in Figure 2.2.1-1.

- **“Enter” button:** used to open the main menu and enter the sub-menus. It is also used to save a value that has been set.
 - **Long press:** opens the Main Menu when on the Main Screen.
 - **Short press:** selects the sub-menu when in the menus.
- **“Back” button:** used to move back one level when in the menus and toggle the direction between forward and reverse when torque operation is enabled.

Note: most menus disable torque operation and thus also the ability to change the direction.

 - **Double short press:** moves back one level in the menu.
 - **Long press:** toggles direction between forward and reverse (disabled in most menus).
- **+ (Plus) button:** increments values and navigates through menus.
- **- (Minus) button:** decrements values and navigates through menus.

Note: A long press is 3-5 seconds.



Figure 2.2.1-1: Tool Interface

2.2.2 Main Screen

The Main Screen is the central interface for the B-RAD X Tool System. The target torque, torque units, and rotational direction are displayed on the Main Screen. Figure 2.2.1-1 shows the layout of the Main Screen.

2.2.3 Audible Status Indicator

The B-RAD X has audible status indicators that inform the user of the tool's status. The audible status indicators include:

- **Start up:** chime.
- **Button press:** short beep.
- **Saved:** pitch up and down sweeping sound indicates the saving of a value that has been changed.
- **Error:** two short beeps then a pause before repeating.
- **Fault:** short beep followed by a lower pitch long beep.

To enable or disable these sounds please see Section 3.4.6 Audio Indication Setting.

2.3 RAD HD Battery Pack



CAUTION!

Only use the RAD HD battery pack with the B-RAD X Tool System. Using third-party batteries will damage the B-RAD X Tool System.

Keep the RAD HD battery pack away from any metal objects. If the battery terminals are connected by a metal object, the battery will short causing damage to the battery and injury to the operator.

The RAD HD battery pack supplies power to the tool; for the B-RAD X to perform best, ensure the RAD HD battery is fully charged and in good condition before use.

Note: The application torque, joint hardness, battery condition, age, and operating temperature will affect the actual number of torque cycles per charge.

2.3.1 Insert/Remove the RAD HD Battery Pack

To insert the RAD HD battery:

1. Ensure the trigger is not depressed.
2. Align the RAD HD battery with the bottom of the tool handle.
3. Slide the RAD HD battery into place until it is fully seated.

Note: A click will confirm that the RAD HD battery is locked in place.

4. Check that the RAD HD battery is locked in place by trying to slide it out of place.
5. For extra safety, slide the red battery lock latch to the right to lock the **"Battery Release"** button in place (Figure 2.3.1-1).

To remove the RAD HD battery:

1. If in the locked position, slide the red battery lock latch to the left to unlock.
2. Press and hold the **"Battery Release"** button and slide the RAD HD battery away from the tool handle.



Figure 2.3.1-1: Battery Release and Lock Out

2.3.2 Check RAD HD Battery Charge

To check the RAD HD battery charge:

- Press the “Charge” button on the RAD HD battery (Figure 2.3.2-1).

Result: The green bars will light up. If all the bars are illuminated, the battery is fully charged. If only one of the bars is illuminated, the RAD HD battery is discharged and needs charging (refer to Section 2.4.1 Charging the RAD HD Battery Pack).

Note: When the battery charge gets too low, the “LoBatt7” will be displayed on the tool LED display.



Figure 2.3.2-1: RAD HD Battery Pack

2.4 RAD Battery Charger



CAUTION!

The RAD HD battery pack should only be charged on the RAD battery charger. If an incompatible charger is used, damage to the RAD HD battery will occur.

The charging status display (Figure 2.4-1) indicates when the RAD HD battery is charging, when the charge is complete, and if there is an error.

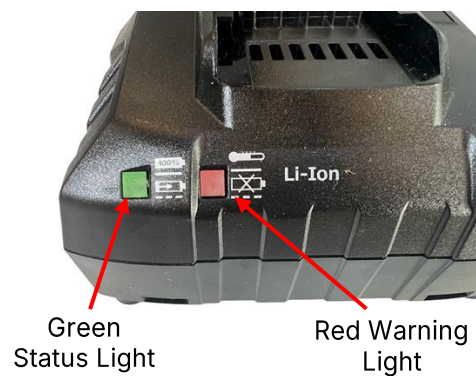

Figure 2.4-1: Charging Status Display

2.4.1 Charging the RAD HD Battery Pack

If the battery was discharged under heavy load, the charger may indicate a battery overtemperature (solid red warning light). This is normal. Keep the battery on the charger while the battery cools. The charging process will start after the battery cools to within its charging temperature range (approximately 15-30 minutes).

Note: The temperature range for charging is 0°C to 40°C (32 °F to 104 °F).

To charge the RAD HD battery:

1. Plug the RAD battery charger into the wall outlet. The red warning light will turn on for one second and then the green status light will turn on for one second.
2. Align the RAD HD battery with the RAD battery charger.
3. Slide the RAD HD battery into place. The green status light will flash while the RAD HD battery is charging.

When the RAD HD battery has been fully charged, the green status light will stop flashing and stay illuminated. Until the RAD HD battery is removed from the RAD battery charger, the charger will maintain the battery charge at maximum capacity.

To remove the RAD HD battery:

1. Slide the RAD HD battery away from the RAD battery charger.
2. Check that the RAD HD battery is fully charged (refer to Section 2.3.2 Check RAD HD Battery Charge).

2.4.2 Charging Errors

The red warning light is on:

The RAD HD battery is not charging because its temperature is not within the required temperature range for charging. When the RAD HD battery's temperature changes to within the required range, the red warning light will turn off and charging will start.

The red warning light is flashing:

The RAD HD battery may be placed incorrectly on the RAD battery charger. Remove the RAD HD battery and replace it correctly on the RAD battery charger. If the red warning light continues to flash, the RAD HD battery is defective; remove the RAD HD battery immediately.

If these problems continue, contact New World Technologies Inc. Technical Support (refer to Section 7. Contact Us) or your RAD distributor.

3.0 INTERFACE AND SETTINGS



CAUTION!

The B-RAD X must be calibrated before first use. If the LED display shows anything other than the Torque Select Screen, the Information Menu, or the Calibration Menu, contact New World Technologies Inc. Technical Support (refer to Section 7. Contact Us) or your RAD distributor.

3.1 Access Levels

Access to the functions on the B-RAD X Tool System has been restricted to four access levels: the Locked level, the Basic level, the Advanced level, and the Distributor level. Access to the higher levels requires an access code. Each level has access to different functions. Table 3.1-1 outlines the functions accessible in each level.





















































Function	Level			
		B	A	D
Enter Access Level Code				
View Tool Information				
Change Set Torque/ Angle				
Change Torque Units				
Change LED Brightness Level				
Change Two-Hand Modes				
Enable/ Disable Angle Mode				
Change Back-Off Angle				
Tool Calibration				
Change Audio Settings				
View Tool Statistics				
Extended Tool Calibration				
Extended Tool Statistics				

Table 3.1-1: Access Levels and Functions

3.1.1 Unlocking Access Levels

The B-RAD X has several different access levels. Table 3.1.1-1 defines the names of access levels, their use cases, and corresponding codes.

To change access levels:

1. Long press “**Enter**” to bring up the Main Menu.
2. Use **+ / -** to navigate to the Lock Menu option, press “**Enter**”.
3. Input the desired access code from the chart below.
4. Press “**Enter**” to accept the new unlock level or press “**Back**” to cancel the entry.

Note: If entering new calibration values is a requirement, then contact New World Technologies’ Customer Support.

	Access Level	Description and Allowed Menus	Access Codes
0	Lock	The user cannot change the torque setting. Only FWD/REV and Lock Menu are active.	- + + -
1	Basic	Change torque value, change torque units, FWD/REV, view Main Menu, view Tool Info, and view Lock Menu.	- - + + - -
2	Advanced	Basic functionality as well as: view and change menu tool settings, and tool calibration	Contact RAD distributor.
3	Distributor	Advanced functionality as well as: extended calibration, and extended tool statistics.	Contact RAD distributor.

Table 3.1.1-1: Access Levels

3.2 Using the Interface

This section covers the various ways to interact with the interface.

3.2.1 Changing the Target Torque

Ensure the tool is on the Main Screen – Torque Select Screen (the torque setting is displayed).

Note: When on the Torque Select Screen, the unit indicator LED is turned on.

Note: To toggle between the Angle Select and Torque Select screens, quick press the “**Enter**” button.

To change the torque value:

1. Press and hold (long press) either of the **+ / -** buttons until a digit starts blinking. The **-** button starts the left-most digit blinking. If the **-** button is pressed and held again, the selected digit moves to the right. The opposite happens with the **+** button.
2. Press the **+** or **-** button quickly to change the digits by one unit at a time. Other digits may be selected (see Step 1) to fine-tune the torque setting.
3. Press the “**Enter**” button to save the selected torque value once it is set to the desired value. The torque value will be saved even when the battery is removed.

With angle enabled on tool:

4. After entering a torque value, the Torque Select Screen will switch to the Angle Select Screen.
5. One of the angle value digits will be blinking and must be confirmed or changed to the desired value (see Section 3.2.2 Changing the Target Angle).
6. Once the angle value has been entered the display will go back to the Torque Select Screen. The torque and angle values will be saved even when the battery is removed.

3.2.2 Changing the Target Angle



CAUTION!

With any angle entered on the tool, the maximum settable torque is 80% of max torque. The tool will automatically change the torque upon entering any angle if the torque is above 80% of max torque. However, the user will be asked to confirm this change during the entry process.

Confirm that the far-right decimal LED is lit up which indicates that angle movement is enabled on the tool (see Section 3.4.4 Angle Enable/Disable Setting).

Ensure the tool is on the Main Screen – Angle Select Screen (the angle setting is displayed).

Note: When on the Angle Select Screen, the unit indicator LED is turned off.

Note: To toggle between the Angle and Torque Select screens, quick press the “Enter” button.

To change the angle value:

1. Press and hold (long press) either of the **+** / **-** buttons until a digit starts blinking. The **-** button starts the left-most digit blinking. If the **-** button is pressed and held again, the selected digit moves to the right. The opposite happens with the **+** button.
Note: The right most digit is reserved for the degree symbol to signify angle so the second digit from the right will be the first adjustable digit.
2. Press the **+** or **-** button quickly to change the digits by one unit at a time. Other digits may be selected (see Step 1) to fine-tune the angle setting.
Note: The angle can be set to anything between 0-9999 degrees.
3. Press the “Enter” button to save the selected angle value once it is set to the desired value.
4. After entering the angle value, the Angle Select Screen will switch to the Torque Select Screen.
5. One of the torque digits will be blinking and must be confirmed or changed to the desired value (see Section 3.2.1 Changing the Target Torque).
6. Once the torque value has been confirmed, the torque and angle values will be saved even when the battery is removed.

3.2.3 Toggling Forward and Reverse

To change the rotational direction between forward and reverse the tool must be on the Main Screen or one of the menus where torque operation is enabled.

Toggling between forward/reverse:

- Press and hold the “Back” button until the forward/reverse indicator LED changes.

3.2.4 Menu Navigation

To enter some menus, an access code is required. Refer to Section 3.1 – Access Levels.

1. To enter the menu from the Main Screen: long press “Enter”.
2. Navigate through the menu using the **+** / **-** buttons.
3. To select the currently displayed menu item: short press “Enter”.
4. To move up one level in the menu: double short press “Back”.
5. To exit the menu: double short press “Back”.

3.3 Basic Level Menu Options

The Basic level menu options are limited to the Lock Menu and the Information Menu.

3.3.1 Information Menu

The Information Menu displays values for gearbox, torque units, low end, high end, serial number and firmware version.

To review information:

1. Long press **"Enter"** until the display changes from displaying torque value to "inFo". This is the start of the menu system.
2. Short press **"Enter"** to view the Information Menu.
3. Use the **+/-** buttons to navigate to the desired information item and press the **"Enter"** button.
4. The selected information will display and scroll across the LED display.

Note: When the user is in the Information Menu, the trigger is disabled.

To return to the Main Menu, press **"Back"** twice. Press **"Back"** twice again to exit the menu system and return to the Main Screen.

Note: For a visual representation of the menu layout and how to get here see Section 3.6 Menu Tree – Overview.

3.3.2 Change Torque Units

See Section 3.4.1 Configuration Menu to navigate to the sub-menu this option is located in.

The Units Menu is used to toggle between ft·lb (foot-pounds) and N·m (newton-meters).

To change torque units:

1. Use the **+/-** buttons to navigate to the Units Menu.
2. Use the **+/-** buttons to toggle between ft·lb (foot-pounds) and N·m (newton-meters).
3. Press **"Enter"** to save a selection. Notice that the LED display has changed to reflect the unit selection.

Note: For a visual representation of the menu layout and how to get here see Section 3.6 Menu Tree Overview.

3.4 Advanced Level Menu Options

The Advanced level menu options are limited to the Basic level menu options (see Section 3.3) as well as the Configuration Menu options and the Statistics Menu.

3.4.1 Configuration Menu

The B-RAD X's Configuration Menu contains all the values that define how the tool behaves during a torque cycle. Values that can be set from the Configuration Menu include units, display brightness, 2-Handed safety settings, back-off settings, calibration settings, and audio indication settings.

To navigate to the Configuration Menu:

1. Long press the **"Enter"** button to bring up the Main Menu.
2. Use the **+/-** buttons to navigate to "conFG", then press **"Enter"**.

Note: For a visual representation of the menu layout and how to get here see Section 3.6 Menu Tree – Overview.

3.4.2 LED Display Brightness

See Section 3.4.1 Configuration Menu to navigate to the sub-menu this option is located in.

The Brightness Menu is used to adjust the brightness level of the LED display.

To change the brightness level of the LED display:

1. Use the **+**/**-** buttons to navigate to "Brightness" and press "**Enter**".
2. Use the **+**/**-** buttons to select desired LED display brightness level.
3. Press "**Enter**" to save the selection.

Note: For a visual representation of the menu layout and how to get here see Section 3.6 Menu Tree – Overview.

3.4.3 The 2-Hand Safety Setting

See Section 3.4.1 Configuration Menu to navigate to the sub-menu this option is located in.

The 2-Hand Menu is used to set the safety setting for how both hands should interact with the tool during a cycle. Enabling it greatly reduces the chance that a hand gets pinched by the reaction arm.

Settings available:

- "**Off**": 2-Hand setting is disabled and only the trigger needs to be pressed to initiate torquing by the tool.
- "**Start**": while the trigger is pressed, the "**Back**" or **-** button must be pressed once to initiate torquing by the tool.
- "**oPrtn**": while the trigger is pressed, the "**Back**" or **-** button must be pressed during the entire cycle to keep the tool torquing.

To change the 2-Hand setting:

1. Use the **+**/**-** buttons to navigate to "2hand" and press "**Enter**".
2. Use the **+**/**-** buttons to navigate to the desired settings.
3. Press "**Enter**" to save the selection.

Note: For a visual representation of the menu layout and how to get here see Section 3.6 Menu Tree – Overview.

3.4.4 Angle Enable/Disable Setting

See Section 3.4.1 Configuration Menu to navigate to the sub-menu this option is located in.

The torque and angle setting is used to turn on torque and angle operation.

To enable/disable the angle setting:

1. Use the **+**/**-** buttons to navigate to "Angle" and press "**Enter**".
2. Use the **+**/**-** buttons to choose between "Off" and "On".
3. Press "**Enter**" to save the selection.

Note: Angle defaults to 0 degrees when Torque and Angle Mode is first turned on.

Visual queues and changes:

- The far-right decimal LED lights up as a visual reminder that angle movements are enabled on the tool.
- When on the Angle Select Screen, the right most LED digit represents the degree symbol, with the four digits on the left being reserved for the desired angle.
- When on the Angle Select Screen, the unit indicator LED is turned off to help signify that it is on the Angle Select Screen.
- To toggle between the Angle Select and Torque Select screens, quick press the "**Enter**" button.
- With any angle entered on the tool, the maximum settable torque is 80% of max torque. The tool will automatically change the torque upon entering any angle if the torque is above 80% of max torque, however, the user will be asked to confirm this change during the entry process.
- There is a short pause when the tool switches from the torque operation over to the angle operation.

- If the trigger is released during an angle operation it will be disabled for 2 seconds to prevent unintended restarts to the cycle.

Note: The angle can be set to anything between 0-9999 degrees.

Note: For a visual representation of the menu layout and how to get here see Section 3.6 Menu Tree – Overview

3.4.5 Back-Off Setting

See Section 3.4.1 Configuration Menu to navigate to the sub-menu this option is located in.

The Back-Off Menu is used to set a value in degrees for the tool to reverse rotation after the tool achieves the set torque. The maximum back-off angle is 90 degrees.

To change the back-off setting:

1. Use the **+**/**-** buttons to navigate to back-off and press **"Enter"**.
2. Use the **+**/**-** buttons to set a back-off value in degrees.
3. Press **"Enter"** to save the selection.

Note: For a visual representation of the menu layout and how to get here see Section 3.6 Menu Tree – Overview.

3.4.6 Audio Indication Setting

See Section 3.4.1 Configuration Menu to navigate to the sub-menu this option is located in.

The Audio Indication Menu is used to mute the audio indications for button presses, startup, or all sounds.

To change the audio indication settings:

1. Use the **+**/**-** buttons to navigate to "Audio" and press **"Enter"**.
2. Use the **+**/**-** buttons to choose from boot, mute, and button settings.
 - Boot: choose between "Default" or "None"
 - Mute: choose between turning all the sounds "On" or "Off"
 - Button: choose between "On" or "Off"
3. Press **"Enter"** to save the selection.

Note: For a visual representation of the menu layout and how to get here see Section 3.6 Menu Tree – Overview.

3.4.7 Statistics Menu

The Statistics Menu contains a record of the number of cycles in certain torque ranges in the tool.

Viewable values:

- **"Total"**: The Total Menu is used to log the total number of cycles by the tool.
- **"00-20", "20-80", "80-99"**: view cycle counts in various torque ranges.
Example: "00-20" logs the number of cycles that occur between 0% and 20% of the maximum torque value.
- **"Over"**: view of cycles in the range of the maximum torque for the tool.

To view a cycle count option:

1. Use the **+**/**-** buttons to navigate to the desired menu option value, press **"Enter"**.
2. The number that is displayed is the cycle count for that torque range.

Note: For a visual representation of the menu layout and how to get here see Section 3.6 Menu Tree – Overview.

3.5 Display Mode – Torque vs. Table

The B-RAD X Tool System has two different display modes that can be toggled between. There is Basic Display Mode known as the Torque Mode and Select Display Mode known as Table Mode.

Note: The B-RAD X Tool System's is by default set to Basic Display Mode (Torque Mode).

Display Modes:

Basic Display Mode – Torque Mode (default): The main screen displays the target torque in the units to which the tool is set. Each digit of the torque value may be set using the **+**/**-** buttons (see Section 3.2.1 Changing the Target Torque).

Select Display Mode – Table Mode: The main screen displays the target torque as level from 1-50. The level can be changed by using quick presses of the **+**/**-** buttons.

To calculate the approximate torque value at a desired level, use the following formula:

$$\text{Value at desired level number} = (\text{Number} - 1) \times \text{MAX} \times 0.018367 + \text{MIN}$$

	Description	Toggle Code
Display Mode Toggle	Toggles between Basic Display Mode (Torque Mode), which is default, and Select Display Mode (Table Mode).	--++

Table 3.5-1: Display Mode Toggle Code

3.6 Menu Tree - Overview

Table 3.6-1 is an overview of the menu system that can be seen in Basic and Advanced access levels. For help navigating the menus See Section 3.2.4 Menu Navigation.

Note: A bold description means it will take the tool to the next menu tree level.

Key	Menu Level 1	Menu Level 2	Menu Level 3	Display	Description	Values (Bold is Default)	Trig.
Basic	inFo			inFo	Display Information Menu		Off
		GbGH		Gbox	Shows gearbox max and units	Text	Off
		unitS		unitS	Displays torque units	ft·lb / N·m	Off
		LoEnd		LoEnd	Minimum allowable torque	Torque	Off
		hiEnd		hiEnd	Maximum allowable torque	Torque	Off
		SEr		SEr	Tool ID (Serial #)	Number	Off
		uivEr		uivEr	User interface software version	Numbers	Off
		hcvEr		hcvEr	Hardware control software version	Numbers	Off
		conFG		conFG	Configuration Menu		Off
			unitS	unitS	Change torque units	ft·lb / N·m	Off
Advanced		brGht		brGht	Change LED brightness level	1-5, 4	Off
		2hAnd		2hAnd	Change Two-Hand Modes	Off / Start / Operate	Off
		AnGLE		AnGLE	Enable/Disable Angle Mode	Off / On	Off
		b-oFF		b-oFF	Change the back-off angle	0-90, 10	Off
		cALib		cALib	Calibration Menu		Off
			cE_hi	cE_hi	High calibration energy level	50-100%, 70%	On
			cE_Lo	cE_Lo	Low calibration energy level	0-50%, 10%	On
			cP 01	cP 01	Set calibration point 1	Actual Torque	On
				...	Set calibration point 2-7	Actual Torque	On
			cP 08	cP 08	Set calibration point 8	Actual Torque	On
		SAvE	SAvE	Save calibration table		Off	

Advanced		Audio		Audio	Audio Menu		Off
			boot	boot	Boot chime	Default / None	Off
			mutE	mutE	Mute entire tool	On / Off	Off
			butto	butto	Button sounds	On / Off	Off
	StAtS			StAtS	Statistics Menu		Off
		total		total	Total # of cycles on this tool	Number	Off
		00-20		00-20	# of cycles in 0-20% range	Number	Off
		20-80		20-80	# of cycles in 20-80% range	Number	Off
		80-99		80-99	# of cycles in 80-99% range	Number	Off
		ovEr		ovEr	# of cycles above 100%	Number	Off
All	Lock		Lock	Enter access level code	+ / - button combo	Off	

Table 3.6-1: Menu Tree

4.0 GENERAL OPERATING INSTRUCTIONS



CAUTION!

Only qualified personnel with training in the safe operation of torque tooling and the B-RAD X should operate this tool. Refer to the Important Safety Notice for more information.

4.1 Reaction Arm



WARNING!

Always keep body parts clear of the reaction arm when the B-RAD X is in use. Serious injury could occur.

CAUTION!

Ensure that the reaction arm has a solid contact point before operating the B-RAD X.

Improper reaction will void warranty and can cause premature tool failure.

Please contact New World Technologies Inc. or your local RAD authorized distributor for information on custom reaction arms.

Installing the Reaction Arm

Slide the reaction arm onto the serpentine fitting and secure the snap ring to hold the reaction arm in place. Couple the socket and square drive together with a dowel pin and secure with a locking ring.

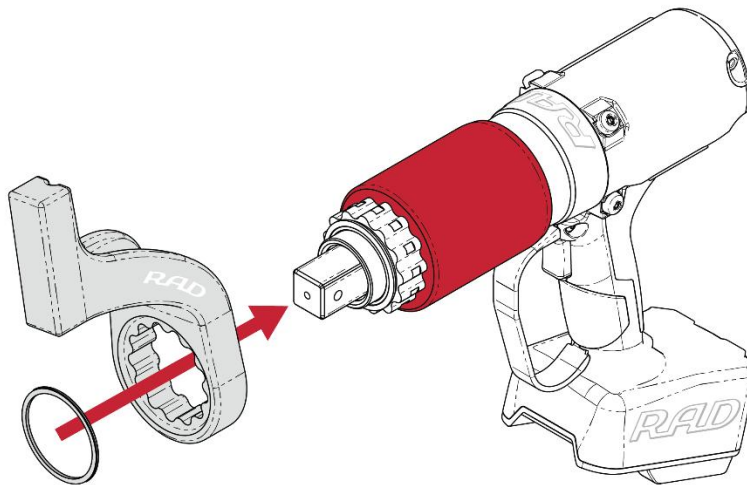

Reaction Points

Make sure that the reaction arm is in contact with a solid reaction point before operating the tool.

When the tool is in operation, the reaction arm rotates in the opposite direction to the output square drive and must be allowed to rest squarely against a solid object or surface adjacent to the bolt to be tightened.

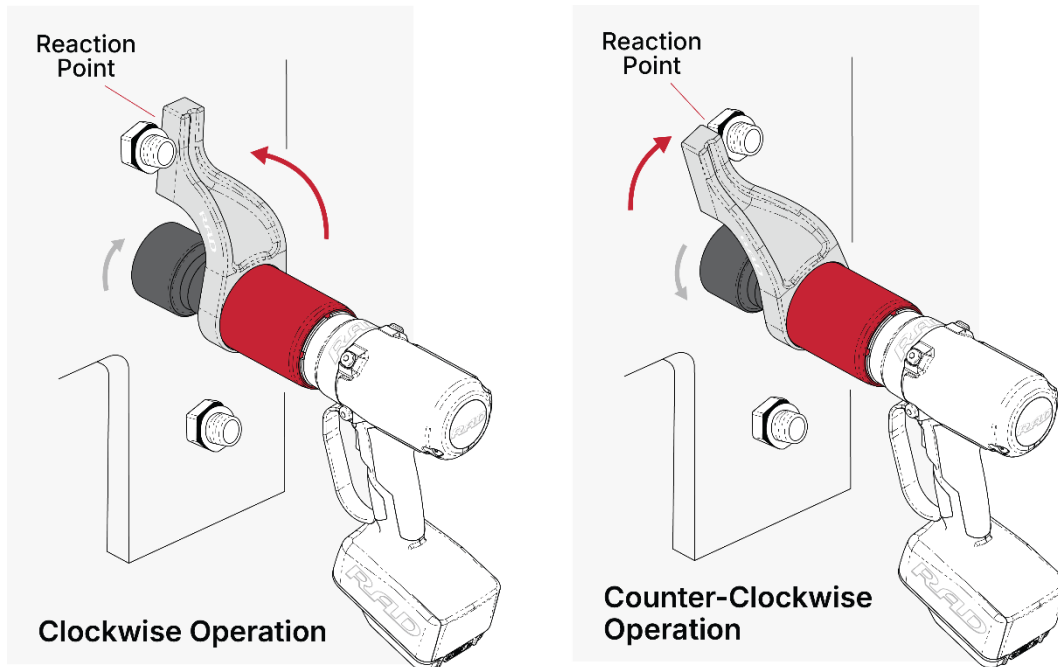

Personal Safety



CAUTION!

Keep hands clear of the reaction arm and joint when the tool is in operation.



Reaction Arm Height

For proper tool function, ensure that the height of the socket is even with the height of the reaction arm.

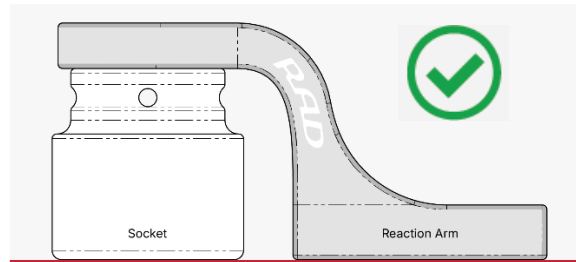

Correct: The socket and reaction arm are aligned

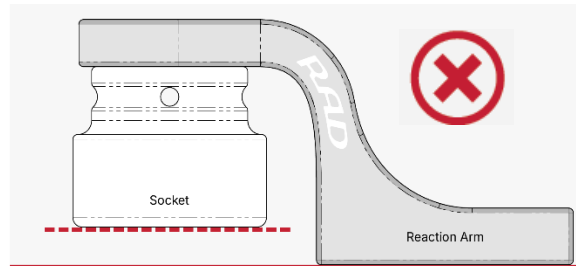
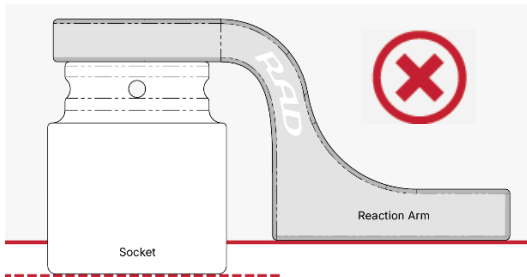

Incorrect: The leg of the reaction arm is too short in the left image and too long in the right image

Reaction Arm Foot

Make sure the foot of the reaction arm is positioned directly against the reaction point to ensure correct function

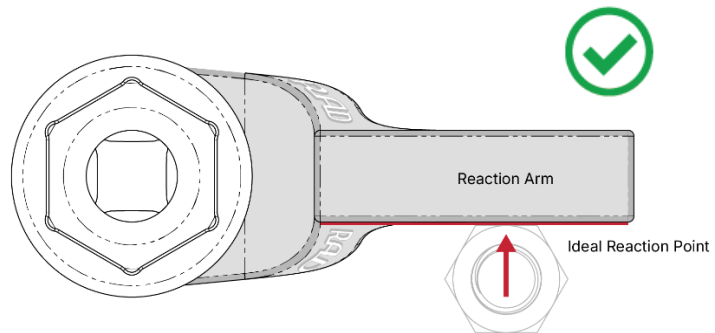

Reaction Point

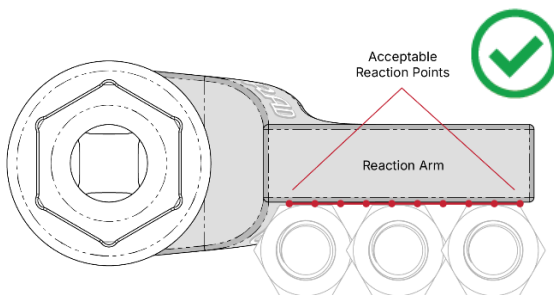

Good reaction point:
Reacting perpendicular to the reaction arm

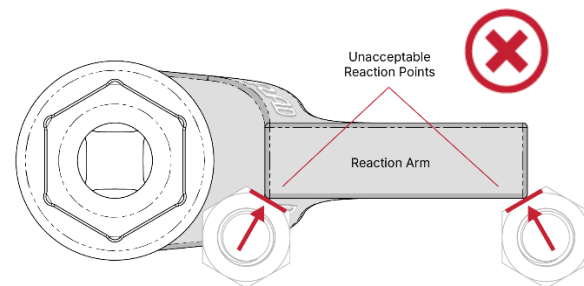

Bad reaction point:
Reacting at the angle towards the heel or the toe of the reaction arm

4.2 Collet Output Carrier Tool



CAUTION!

Failure to properly tighten the collet can allow the square drive and the socket to disconnect from the tool. This may cause injury to the operator and/or damage to the application.

How to replace the output square drive:

1. Use the collet wrench provided in the tool kit (Figure 4.2-1) to loosen the collet.
Note: If the tool has the compression nut option instead of the collet, a regular spanner wrench can be used.



Figure 4.2-1: Collet Wrench

2. Pull the square drive away from the handle to remove.
3. Slide the new square drive, compression collar (Figure 4.2-2) and collet on as in Figure 4.2-3 for a B-RAD X 3000 or as in Figure 4.2-4 for B-RAD X 5000.



Figure 4.2-2: Compression Collar

Note: Be sure the compression collar is inserted with the thinner edge towards the handle. Failure to do this will result in improper pressure holding the square drive.

4. Use the collet wrench to tighten the collet.

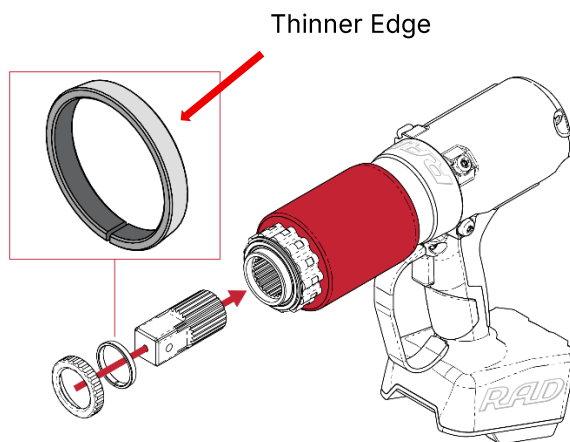

Figure 4.2-3: B-RAD X 3000 Collet Output Carrier

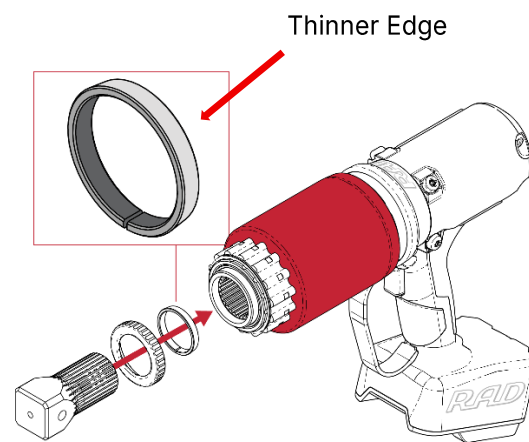

Figure 4.2-4: B-RAD X 5000 Collet Output Carrier

4.3 Torque Operation

To operate the tool in a torque cycle:

1. Ensure the tool is on the Main Screen.
2. Ensure the LED display is showing the correct units.
3. Change the torque value as needed (see Section 3.2.1 Changing the Target Torque).
4. The B-RAD X is ready to torque at the displayed setting.
5. Place the B-RAD X on the joint system and ensure the LED display indicates forward rotation.
6. Press and hold the trigger.
7. To stop the torque cycle, release the trigger at any point in the cycle.
8. When the B-RAD X reaches the target torque value, the reaction arm will back-off from the reaction point, and the tool will stop turning. Release the trigger.

4.4 Torque and Angle Operation



CAUTION!

Do not perform torque and angle cycles that will result in final torques which are at or above the maximum torque limit of the tool (See Section - 1.2.1 Tool Model Specifications) as operating outside of the tool's set range may produce unintended results and/or cause damage to the tool.

Confirm that the far-right decimal LED is lit up which indicates that angle movement is enabled on the tool (see Section 3.4.4 Angle Enable/Disable Setting).

To operate the tool in a torque and angle cycle:

1. Ensure the tool is on the Main Screen – Angle Select Screen or Torque Select Screen.
Note: To toggle between the Angle Select and Torque Select screens, quick press the “Enter” button.
2. On the Torque Select Screen, check that the LED display is showing the correct units.
Note: When on the Torque Select Screen, the unit indicator LED is turned on.
When on the Angle Select Screen, the unit indicator LED is turned off.
3. Change the torque and angle value as needed (see Section 3.2.2 Changing the Target Angle).
4. The B-RAD X is ready to perform a cycle at the displayed settings.
5. Place the B-RAD X on the joint system and ensure the LED display indicates forward rotation.
6. Press and hold the trigger.
7. To stop the torque cycle, release the trigger at any point in the cycle.
8. When the B-RAD X reaches the target torque value, there will be a short pause before the tool switches over to the angle operation.
9. Once the B-RAD X reaches the target angle value, the reaction arm will back-off from the reaction point, and the tool will stop turning. Release the trigger.

Note: If the trigger is released during an angle operation it will be disabled for 2 seconds to prevent unintended restarts to the cycle.

5.0 CALIBRATION



CAUTION!

Only qualified personnel with training in the safe operation of torque tooling and the B-RAD X Tool System should operate this tool. Improper use of the calibration function will result in tool damage.

Do not calibrate at target torques that result in exceeding the B-RAD X's torque range. Severe tool damage will occur.

This function allows the operator to access the calibration values for the B-RAD X. These values should only be modified by a qualified calibration technician and using a calibration stand.

The tools may only be calibrated with the 5.5Ah and 8.0Ah batteries. The ability to enter calibration will be locked out if a 5.2Ah or 10Ah battery is connected, with the message "cALib_diSAbLEd_chG_btt" scrolling across the display.

5.1 Calibration Menu Navigation

The Calibration Menu allows for the modification of the values for CE high, CE low, and calibration points 1-8.

The full calibration table won't be saved unless the save option is selected and "**Enter**" is pressed.

Note: The tool will go into "Calibration Recovery" if the power is lost without exiting calibration beforehand. See Section 5.1.1 Calibration Recovery for more information.

Ensure the correct access level is enabled, See Section 3.1.1 Unlocking Access Levels.

To enter the Calibration Menu:

1. From the Main Screen enter the Main Menu with a long press of the "**Enter**" button
2. Navigate to and enter the "conFG" Menu.
3. Then navigate to and enter the "cALib" Menu.

5.1.1 Calibration Recovery

The tool has "Calibration Recovery" which it will go into if the power is lost or the battery is removed without exiting calibration before the loss of power.

This means that when the tool is powered down while it is still in the calibration menus, when it powers back on it will return to the calibration menu. Previously set values will still be set and the calibration can continue where it was left off.

This feature is useful when needing to change out batteries in the middle of a calibration.

5.2 Table of Calibration Menus

The order and function of the menus in the Calibration Menu are outlined in Table 5.2-1 below.

Note: If any changes are made in the calibration menu, the save option will need to be selected.





Key	Calib	Description	Values (Bold is Default)	Trigger	
Advanced		cE_hi	High calibration energy level	50-100%, 70%	Enabled
		cE_Lo	Low calibration energy level	0-50%, 10%	Enabled
		cP 01	Set calibration point 1	Actual torque	Enabled
		...	Set calibration point 2 - 7	...	Enabled
		cP 08	Set calibration point 8	Actual torque	Enabled
		SAvE	Save calibration table		Disabled

Table 5.2-1: Calibration Menu

5.3 Calibration Procedure

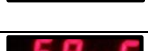

CAUTION!

DO NOT operate the B-RAD X Tool System beyond 50 units above the rated maximum torque. Over-torquing the tool will cause severe tool damage.

See Section 3.1 Access Levels to ensure the correct access level is enabled. Some settings in calibration are restricted to higher levels.

To calibrate the B-RAD X Tool System:

- Install a fresh battery into the B-RAD X.
Note: If a battery drains during calibration, a fresh battery can be inserted without losing any settings previously set. Upon reboot, the tool will recover the settings already set and position in the menu from before shutting down.
- Before any calibration points are set, it is recommended that the tool is warmed up near the tool's maximum setting. While on the "cE_hi" setting press "**Enter**" to enter the setting and enable the tool.
Note: Do approximately 10 cycles around the maximum torque to warm up the tool.
- Perform a torque cycle on the calibration stand.
- Using the **+**/**-** buttons, gradually increase or decrease the setting until the torque readings nearly match the maximum torque of the tool. Adjust the value to achieve approximately 50 units above maximum torque.
Note: make sure to press "**Enter**" after changing the value to save the value and re-enable the tool.
- Once "cE_hi" is set and the 10 warm-up cycles are complete, double press "**Exit**" to get back into the Calibration Menu.
- Advance to the "cE_Lo" setting and press "**Enter**" to enter the setting and enable the tool.
- Take a pull at the default setting.
- Using the **+**/**-** buttons, gradually increase or decrease the setting until the torque readings nearly match the minimum torque of the tool. Adjust the value to achieve approximately 50 units below the tool's minimum torque.
Example: a 5000 ft·lb tool has a minimum of 500 ft·lb, so the torque to be reached would be 450 ft·lb. See Section 1.2.1 Tool Model Specifications for a full list of B-RAD X Tool ranges.
Note: make sure to press "**Enter**" after changing the value to save the value and re-enable the tool.
- Once "cE_Lo" is set, double press "**Exit**" to get back into the Calibration Menu.

10. Advance to the "cP 01" setting and press "**Enter**" to enter the setting and enable the tool.
11. Perform one cycle at "cP 01" and record the measured torque value.
12. Enter the measured torque value into the tool using the **+** / **-** buttons. Once set press "**Enter**" to save the value in the tool.
13. Double press "**Exit**" and navigate to the next calibration point in the menu.
14. Repeat Steps 11-14 for the each of the calibration points.
15. Once all calibration points are set, save and exit calibration by pressing "**Enter**" on the Save Screen.
Note: If the units are changed using the Config Menu (see Section 3.3.2 Change Torque Units), the units of calibration values will be converted in the Calibration Menu.

6.0 TROUBLESHOOTING



IMPORTANT!

Disassembling or attempting repair will void warranty.

If breakdown, malfunction, or error occurs, contact New World Technologies Inc. Technical Support (refer to Section 7. Contact Us).

The display module may show abnormal behaviour depending on operating conditions, frequency of use, or excessive wear on the display module.

The display module is designed to withstand normal use over the lifetime of the B-RAD X Tool System, however, as a sensitive electronic device it is susceptible to damage caused by shock, moisture, or excessive force.

6.1 Faults and Errors

6.1.1 Errors

Errors indicate abnormal conditions prior to making a torque cycle. The following is a table that indicates errors the B-RAD X can detect and potential solutions.

Error Display	Problem	Solution
cALib_diSAbLEd_chG_btt	The battery plugged in is not usable for calibrating the tool (ex: 5.2Ah or 10Ah battery).	Replace the battery with a battery that is acceptable for calibrating, such as a 5.5Ah or 8.0Ah battery.
Lo Batt-0	The battery plugged in has lower than usual voltage; or if using Twin Battery Adapter, one of the two batteries or both have lower than usual voltage.	The battery may be damaged or extensively drained. Try charging the battery. Replace battery.
B-Hot-1	The battery temp is too high; or if using Twin Battery Adapter, one or both batteries are too hot.	Allow the battery to cool or replace battery with another fresh battery.
T-Hot-2	Motor temperature is too high.	Wait until the tool has cooled down. Check if fan intake is blocked.
T-Hot-3	The board temperature is too high.	Wait until the tool has cooled down. Check if fan intake is blocked.
E-04	Over torque error.	Power cycle tool.
E-05	Over angle error.	Power cycle tool.
ChGE Batt-6	Unrecognized battery.	Replace battery.
Lo Batt-7	Battery is low.	Replace battery.
ChGE Batt-8	The battery is low or too old to continue; if using Twin Battery Adapter, one or both batteries are low or too old to continue.	Replace battery.
ChGE Batt-9	Battery has comms error.	Replace battery.

TCold-11	Motor temp is too cold.	Warm up tool. If the error persists, contact RAD or a RAD distributor.
TCold-12	Board temp is too cold.	Warm up tool. If the error persists, contact RAD or a RAD distributor.
ChgeBatt-13	Battery is of invalid type.	Replace battery.
Bcold-14	Battery temp is too cold; if using a Twin Battery Adapter, one of the batteries temps is too cold.	Replace with warmer battery.
E-19	Twin Battery Adapter cannot communicate with one of the batteries.	Replace batteries.
E-20	If using Twin Battery Adapter, one of the temperature sensors has broken open.	Replace Twin Battery Adapter.
E-21	The voltage detection is broken on Twin Battery Adapter.	Replace Twin Battery Adapter.
E-22	Wrong battery types plugged in at the same time.	Plug in correct battery types.
E-23	Tool can no longer communicate with the Twin Battery Adapter.	Replace Twin Battery Adapter.

Table 6.1.1-1: Errors List

6.1.2 Operating Errors

Operating errors indicate abnormal conditions during a torque cycle. The following is a table that indicates errors the B-RAD X can detect and the explanation.



Error Display	Error Meaning
	<ol style="list-style-type: none"> The user is pulling the trigger in a menu that does not allow for use of the tool while it is open. If the tool is on the Main Screen, the tool is not calibrated. Contact your RAD distributor.
	The tool starts a torque/ torque and angle cycle, and the trigger is released before the target or pre-torque value is reached.
	The tool stops the cycle before the angle movement is completed to avoid overtorquing.

Table 6.1.2-1: Operating Errors

6.1.3 Faults

When a fault is shown, it is followed by a number. This indicates a hardware anomaly has occurred and the tool needs to be sent to the nearest repair facility for repairs. Contact RAD or a RAD distributor, report the fault code and describe the conditions before the fault occurred to determine if the tool needs to be sent for repair.

Report the following information/conditions prior to a fault:

- Tool model, serial number, software versions.
- Torque setting of the tool.
- Battery state of charge.
- Number of torque cycles in a row and length of each torque cycle.

Fault Display	Fault Meaning
FLT1	Idle Over Current.
FLT2	Encoder Fault.
FLT3	Driver Fault.
FLT4	No Current Fault into Motor.
FLT5	UI Board Fault – Invalid Board Detected.
FLT6	Quad Encoder Fault.
FLT7	Motor Stall Fault.
FLT10	Voltage Detection Fault.
FLT11	Bridge Comms Fault.
FLT12	Current Sensing Fault.
FLT13	MCU Init Fault.
FLT17	UI Board Comms Fault.
FLT18	MCU/UI Synchronization Fault
FLT19	MOSFET Failure Fault

Table 6.1.3-1: Faults List







7.0 CONTACT Us

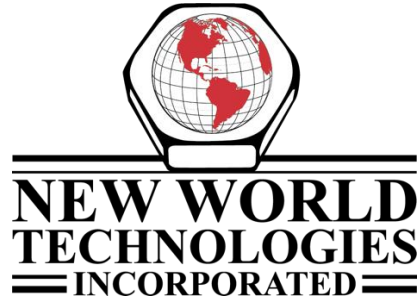

TF: 1-800-983-0044 **F:** 604-852-0269

W: www.radtorque.com **E:** info@radtorque.com

Technical Support

P: 1-800-983-0044 (EXT. 227)

E: service@radtorque.com

New World Technologies Inc.

100-30722 Marshall Road
Abbotsford, BC V2T 0H9
Canada



The Bluetooth® word mark and logos are registered trademarks of Bluetooth SIG, Inc. and any use of such marks by New World Technologies Inc. is under license. Other trademarks and trade names are those of their respective owners.

B-RAD X LIMITED WARRANTY

NEW TOOL WARRANTY

Any new tool branded with the RAD name and purchased from New World Technologies Inc., or through one of its authorized distributors or agents, is warranted to the original purchaser against defects in materials and workmanship for a period of one (1) year from the date of original calibration. Electric drive components such as electric motors, switches, and batteries etc., are covered for a period of six (6) months from the date of original calibration. Under the terms of this warranty, New World Technologies Inc., at its option and F.O.B. either its factory or an authorized service center, will replace or repair for the original purchaser, free of charge, any part or parts, found upon examination by New World Technologies Inc., to be defective in material or workmanship or both. If any product or part is replaced or repaired under the terms of this warranty, that product or part will carry the remainder of the warranty from the date of original calibration.

REPAIRED TOOL WARRANTY

Once a tool is beyond its new tool warranty, New World Technologies Inc., for a period of three (3) months from the date of repair, will replace or repair for the original purchaser, free of charge, any part or parts, found upon examination by New World Technologies Inc., to be defective in material or workmanship or both. If any product or part is replaced or repaired under the terms and conditions of this warranty, that product or part will carry the remainder of the warranty from the date of original repair.

To qualify for the above mentioned warranties, written notice to New World Technologies Inc. must be given immediately upon discovery of such defect, at which time New World Technologies Inc. will issue an authorization to return the tool. The defective item must promptly be returned to New World Technologies Inc. all freight charges prepaid. When returning a tool, the reaction arms being used with the tool must also be returned.

NEW WORLD TECHNOLOGIES INC. | T: 1.800.983.0044 | E: INFO@RADTORQUE.COM

EXCLUSIONS FROM WARRANTY

Tools or accessories found by New World Technologies Inc.'s sole judgment to have been altered, damaged, misused, abused, badly worn due to excessive utilization, lost, or improperly maintained will NOT be covered under the terms of this warranty.

Tools returned without the reaction arms will not be covered under the terms of this warranty.

Consumable parts and accessories (such as extensions, reaction blanks/arms) are not covered under this warranty.

Tools that have been relabeled without prior written consent of New World Technologies Inc. will not be covered under this warranty.

Equipment and accessories not manufactured by New World Technologies Inc. (measuring equipment, etc.) are warranted only to the extent of the original manufacturer's warranty.

**There is no other express warranty. Implied warranties, including those of merchantability and fitness for a particular purpose are limited to one year from date of calibration and to the extent permitted by law. Liability for consequential damages under any and all warranties are excluded to the extent exclusion is permitted by law.*

LIGHTER FASTER STRONGER SAFER



ABOUT NEW WORLD TECHNOLOGIES INC.

New World Technologies is a leading Canadian manufacturer of pneumatic, battery powered, and electronic pistol grip torque wrenches. Our advanced products have proven to be successful all over the world in such industries as oil and gas, petrochemical, mining, aerospace, and manufacturing. We continue to invest in and employ the latest technology to achieve the highest level of Innovation, quality, and performance - which has resulted in multiple patents for our products.



NEW WORLD TECHNOLOGIES INC

#100 - 30722 MARSHALL RD | ABBOTSFORD, BC V2T 0H9 | CANADA
604.852.0405 | INFO@RADTORQUE.COM | RADTORQUE.COM