



ADVANCED
BOLTING
TECHNOLOGY



PNEUMATIC



ELECTRONIC



BATTERY



ELECTRIC



SMART SOCKET

WWW.RADTORQUE.COM

B-RAD S
USER MANUAL

RAD TORQUE SYSTEMS

PNEUMATIC SERIES



- **PATENTED PLANETARY GEAR REDUCTION**
Delivers one of the highest power-to-weight ratios of any pneumatic controlled bolting system
- **SMOOTH CONTINUOUS FLOW OF CONTROLLED TORQUE**
Eliminates destructive hammering
- **LIGHTWEIGHT ERGONOMIC PISTOL GRIP DESIGN**
Reduces operator strain and injury; resulting in increased productivity
- **UNMATCHED RELIABILITY AND QUALITY**
Delivered by one of the most advanced engineered gear boxes on the market

ELECTRONIC SERIES E-RAD



- **PUSH-BUTTON SELECT TORQUE**
Fast and convenient error-free digital single increment torque settings
- **DIGITAL TORQUE CONSOLE DISPLAY**
Maximum accuracy by seeing the set torque value and the actual delivered torque value
- **LIGHTWEIGHT AND ERGONOMIC PISTOL GRIP DESIGN**
Advanced low-profile handle to reduce operator fatigue and increase productivity
- **EXTREMELY LOW NOISE LEVEL ONLY 75DB**
World's quietest extreme torque gun, ideal for sensitive environments and standards
- **LED GREEN (PASS) OR RED (FAIL) INDICATOR LIGHTS**
Unmistakable visual signal indicates status of torque procedure for maximum accuracy and speed

BATTERY SERIES B-RAD



- **QUICK ADJUST TORQUE SETTINGS**
Fast and accurate "dial a torque" for maximum versatility and efficiency
- **SOFT-START VARY SPEED TRIGGER**
Allows operator to safely and quickly set reaction arm before full torque is applied
- **EQUAL POWER IN FORWARD AND REVERSE**
Convenience and cost effective use of same tool for break away and final torque
- **IMAGINE THE FREEDOM - NO AIR LINES, NO POWER CORDS!**
The lightweight design of the B-SERIES makes it ideal for any application, especially where compressed air and electricity are not readily available.
- **ADVANCED GEARBOX DESIGN**
PATENTED planetary gear reduction drive system delivering one of the highest power-to-weight ratios of any controlled bolting system

ELECTRIC SERIES V-RAD



- **QUICK ADJUST TORQUE SETTINGS**
Fast and accurate "dial a torque" for maximum versatility and efficiency
- **SOFT-START VARY SPEED TRIGGER**
Allows operator to safely and quickly set reaction arm before full torque is applied
- **EQUAL POWER IN FORWARD AND REVERSE**
Convenience and cost effective use of same tool for break away and final torque
- **ADVANCED ULTRA-DURABLE ELECTRIC MOTOR DESIGN**
Extreme duty designed to reduce maintenance cost and increase reliability
- **ADVANCED GEARBOX DESIGN**
Patented planetary gear reduction drive system delivering one of the highest power-to-weight ratios of any controlled bolting system

SMART SOCKET™ SERIES



- **MEASURE AND DISPLAY PEAK TORQUE**
Transducer technology combined with a custom socket measures the actual torque applied to the bolt during a torque cycle.
- **PASS OR FAIL INDICATION**
Unmistakable digital signal indicates peak torque achieved for maximum accuracy
- **BLUETOOTH® TECHNOLOGY**
View and download logs onto your smartphone or tablet
- **IDEAL ON SITE CALIBRATION TOOLS**
Comparable in size to a standard socket, it's the perfect tool for inspecting bolted joints and can function as a master calibrator for your torque tools

NOTICE:

This manual applies to the following hardware and firmware release:

B-RAD S V2.0_22.1107**TABLE OF CONTENTS**

Table of Contents	1
Manual Revision History	3
Important Safety Notice.....	4
General Power Tool Safety Warnings	4
Battery Pack Safety Warnings	6
Symbol Identification	7
1.0 General Information	8
1.1 System Components	8
1.2 Specifications	9
1.2.1 Tool Model Specifications	9
1.2.2 Battery Specifications	9
1.2.3 Environmental Specifications	10
1.2.4 Cycle of Operation	10
2.0 Tool System.....	11
2.1 Tool Handle.....	11
2.1.1 Trigger Lock.....	11
2.2 Display Interface.....	12
2.2.1 Keypad	12
2.2.2 Key Lock.....	13
2.2.3 Main Screen.....	13
2.3 RAD Li-Ion Battery Pack.....	13
2.3.1 Insert/Remove the RAD Li-Ion Battery Pack.....	13
2.3.2 Check RAD Battery Charge	14
2.4 RAD Battery Charger	14
2.4.1 Charging the RAD Li-Ion Battery Pack.....	15
2.4.2 Charging Errors	15
3.0 B-RAD S Functions	16
3.1 Unlock Levels.....	16
3.1.1 Unlocking Access Levels.....	17
3.1.2 Returning to the Basic Level	17
3.2 Basic Level Functions.....	17
3.2.1 Change the Target Torque.....	18
3.2.2 Change the Target Angle	18
3.2.3 Select Preset – Customerpreset	19
3.2.4 Select Preset – HV-Preset.....	20
3.2.5 Norm-Program Mode	20
3.2.6 Check-Program Mode.....	21
3.2.7 View Log File	21
3.2.8 Statistics – Cycle Counts.....	22
3.2.9 Information	22
3.2.10 Diagnosis.....	23
3.3 Advanced Level Functions.....	24
3.3.1 Save Preset – Customerpreset	24
3.3.2 Settings – Angle Enable/Disable	25
3.3.3 Settings – Limits	26
3.3.4 Settings – Bolt Counter.....	26



3.3.5 Settings – Adjustment Lock.....	27
3.3.6 Settings – Counterclockwise (CCW) Cycle.....	28
3.3.7 Settings – Torque Sensor Enable/Disable.....	28
3.3.8 Settings – Point Calibration Setup.....	29
3.3.9 Settings – Unit Selection	30
3.3.10 Settings – Language Selection	30
3.3.11 Settings – Back-off Setup.....	31
3.3.12 Maintenance – Delete Maintenance Cycles	31
3.3.13 Data Logging – Choose Log File.....	32
3.3.14 Data Logging – Date/Time Setup.....	32
3.3.15 Data Logging – Settings – Worker-ID	32
3.3.16 Data Logging – Settings – Data Transfer.....	33
4.0 General Operating Instructions	34
4.1 Reaction Arm	34
Installing the Reaction Arm.....	34
Reaction Points.....	35
Personal Safety.....	35
Reaction Arm Height.....	36
Reaction Arm Foot.....	36
Reaction Point.....	36
4.2 Torque Operation.....	37
4.3 Torque and Angle Operation	37
4.4 Check-Program Mode Operation.....	38
5.0 Calibration.....	39
5.1 Entering Calibration Mode	39
5.2 Table of Calibration Menus	40
5.3 Calibration Procedure.....	41
5.4 Sensor Calibration Procedure	42
6.0 B-RAD Data Logger.....	43
6.1 Downloading the B-RAD Data Logger.....	43
6.2 Pairing the Tool.....	43
6.2.1 Opening the Bluetooth® Menu.....	43
6.2.2 Add a Device to PC	44
6.2.3 Finding COM Ports Over Bluetooth®.....	45
6.3 Downloading Data Logs	46
6.4 Viewing Log Files	47
6.5 Closing Data Logs	48
6.6 Exporting Data Files	49
7.0 Troubleshooting.....	50
7.1 Errors and Solutions.....	50
8.0 Contact Us.....	52

MANUAL REVISION HISTORY

V2020.10.29:

- Initial Manual Release

V2021.02.05:

- Updated: 1.2.1 Tool Model Specifications
- Added Intermediate Unlock level too sections: 3.1 / 3.1.1

V2021.05.03:

- Updated: Figures 1.1-1 / 2.1-1 / 2.2.1-1
- Updated: 4.2 Torque Operation

V2022.01.19:

- Fixed section numbers
- Updated references to centre button from M button

V2022.06.20:

- Update 7.0 Contact Us: New Address

V2023.03.20:

- Update 7.0 Contact Us: New Photo

V2024.12.19:

- Updated: 7.0 Contact Us – Bluetooth® trademark statement

V2026.05.15:

- Reformatting of the Manual
- Updated references from centre button and arrow buttons to RAD button and Plus and Minus buttons
- Updated: Images
- Updated Battery Pack Safety Warnings Section
- Added: Symbol Identification Section
- Added: Section 2.2.2 Key Lock
- Updated: Table 3.1-1
- Updated: Section 3.2.7 View Log File
- Updated: Section 3.3.8 Language Selection
- Updated: Section 3.3.2 Angle Enable/ Disable
- Updated: Section 3.3.3 Settings – Limits
- Updated: Section 3.3.4 Settings – Bolt Counter
- Added: Section 3.3.5 Adjustment Lock
- Added: Section 3.3.6 Counterclockwise Cycle
- Updated: Section 3.3.7 Settings – Torque Sensor Enable/ Disable
- Updated: Section 3.3.8 Settings – Point Calibration Setup
- Updated: Section 4.1 Reaction Arm
- Added: Section 6.0 B-RAD Data Logger

IMPORTANT SAFETY NOTICE



WARNING!

READ ALL SAFETY WARNINGS, INSTRUCTIONS, ILLUSTRATIONS, AND SPECIFICATIONS PROVIDED WITH THIS POWER TOOL. FAILURE TO FOLLOW ALL INSTRUCTIONS LISTED BELOW MAY RESULT IN ELECTRIC SHOCK, FIRE AND/OR SERIOUS INJURY.

SAVE ALL WARNINGS AND INSTRUCTIONS FOR FUTURE REFERENCE.

GENERAL POWER TOOL SAFETY WARNINGS

The term "power tool" in the warnings refers to your battery-operated (cordless) power tool.

The B-RAD S Tool System should be inspected before each use.

1. Work Area Safety

- a. **Keep work area clean and well lit.** Cluttered and dark areas invite accidents.
- b. **Do not operate power tools in explosive atmospheres, such as environments with the presence of flammable liquids, gases, or dust.** Power tools create sparks which may ignite the dust or fumes.
- c. **Keep children and bystanders away while operating the power tool.** Distractions can cause you to lose control.

2. Electrical Safety

- a. **Power tool plugs must match the outlet. Never modify the plug in any way. Do not use any adapter plugs with earthed (grounded) power tools.** Unmodified plugs and matching outlets will reduce the risk of electric shock.
- b. **Avoid body contact with earthed (grounded) surfaces such as pipes, radiators, ranges, or refrigerators.** There is an increased risk of electric shock if your body is earthed (grounded).
- c. **Do not expose power tools to rain or wet conditions.** Water entering a power tool will increase the risk of electric shock.
- d. **Do not abuse the cord. Never use the cord to carry, pull, or unplug the power tool. Keep cord away from heat, oil, sharp edges, and moving parts.** Damaged or entangled cords increase the risk of electric shock.
- e. **When operating a power tool outdoors, use an extension cord suitable for outdoor use.** Use of a cord suitable for outdoor use reduces the risk of electric shock.
- f. **If operating a power tool in a damp location is unavoidable, use a Ground Fault Circuit Interrupter (GFCI) protected supply.** Use of a GFCI reduces the risk of electric shock.

3. Personal Safety

- a. **Stay alert, watch what you are doing, and use common sense when operating a power tool. Do not use a power tool while you are tired or under the influence of drugs, alcohol, or medication.** A moment of inattention while operating power tools may result in serious personal injury.
- b. **Use personal protective equipment and always wear eye protection.** Protective equipment such as a dust mask, non-skid safety shoes, hard hat, and hearing protection used in appropriate conditions will reduce personal injuries.
- c. **Prevent unintentional starting by ensuring the switch is in the off position before connecting to a power source and/or battery pack, picking up, or carrying the tool.** Carrying power tools with your finger on the switch or energizing power tools that have the switch on invites accidents.
- d. **Remove any adjusting key or wrench before turning the power tool on.** A wrench or a key left attached to a rotating part of the power tool may result in personal injury.
- e. **Do not overreach. Keep proper footing and balance at all times.** This enables better control of the power tool in unexpected situations.
- f. **Dress properly. Do not wear loose clothing or jewellery.** Keep your hair, clothing, and gloves away from moving parts.

- g. **If devices are provided for the connection of dust extraction and collection facilities, ensure these are connected and properly used.** Use of dust collection can reduce dust-related hazards.
- h. **Do not let familiarity gained from frequent use of tools allow you to become complacent and ignore tool safety principles.** A careless action can cause severe injury within a fraction of a second.

4. Power Tool Use and Care

- a. **Do not force the power tool.** Use the correct power tool for your application.
- b. **Do not use the power tool if the switch does not turn it on and off.** A power tool that cannot be controlled with the switch is dangerous and must be repaired.
- c. **Disconnect the power source and/or the battery pack from the power tool before making any adjustments, changing accessories or storing power tools.** Such preventive measures reduce the risk of starting the power tool accidentally.
- d. **Store idle power tools out of the reach of children and do not allow persons unfamiliar with the power tool or these instructions to operate the power tool.** Power tools are dangerous in the hands of untrained users.
- e. **Power tools must be properly maintained.** Check for misalignment or binding of moving parts, breakage of parts, and any other condition that may affect the power tool's operation. If damaged, have the power tool repaired before use. Many accidents are caused by poorly maintained power tools.
- f. **Use the power tool and accessories in accordance with these instructions, taking into account the working conditions and the work to be performed.** Use of the power tool for operations different from those intended could result in a hazardous situation.
- g. **Keep handles and grasping surfaces dry, clean and free from oil and grease.** Slippery handles and grasping surfaces do not allow for safe handling and control of the tool in unexpected situations.

5. Battery tool use and care

- a. **Recharge only with the charger specified by the manufacturer.** A charger that is suitable for one type of battery pack may create a risk of fire when used with another battery pack.
- b. **Use power tools only with specifically designated battery packs.** Use of any other battery packs may create a risk of injury and fire.
- c. **When battery pack is not in use, keep it away from other metal objects,** like paper clips, coins, keys, nails, screws or other small metal objects that can make a connection from one terminal to another. Shorting the battery terminals together may cause burns or a fire.
- d. **Under abusive conditions, liquid may be ejected from the battery; avoid contact. If contact accidentally occurs, flush with water. If liquid contacts eyes, additionally seek medical help.** Liquid ejected from the battery may cause irritation or burns.
- e. **Do not use a battery pack or tool that is damaged or modified.** Damaged or modified batteries may exhibit unpredictable behaviour resulting in fire, explosion or risk of injury.
- f. **Do not expose a battery pack or tool to fire or excessive temperature.** Exposure to fire or temperature above 130 °C (265 °F) may cause explosion.
- g. **Follow all charging instructions and do not charge the battery pack or tool outside the temperature range specified in the instructions.** Charging improperly or at temperatures outside the specified range may damage the battery and increase the risk of fire.

6. Service





- a. **Have your power tool serviced by a qualified repair person using only identical replacement parts.** This will ensure that the safety of the power tool is maintained.
- b. **Never service damaged battery packs.** Service of battery packs should only be performed by the manufacturer or authorized service providers.

Battery Pack Safety Warnings

- a. **Only use the RAD HD battery pack with the B-RAD X Tool System.** The use of other batteries with the B-RAD X Tool System will cause damage to the tool.
- b. **The RAD HD battery pack should only be charged on the RAD HD battery charger.** If an incompatible charger is used, damage to the RAD HD battery will occur.
- c. **Follow all charging instructions and do not charge the battery pack or tool outside the temperature range specified in the instructions.** Charging improperly or at temperatures outside the specified range may damage the battery and increase the risk of fire.
- d. **Keep the RAD HD battery pack away from any metal objects.** If the battery terminals are connected by a metal object, the battery will short and will cause damage to the battery and injury to the operator. Even discharged battery packs can cause short circuits because they have a residual charge to protect against a deep discharge. To avoid accidental and unwanted short circuits, insulate the battery contacts of battery packs outside the machine with a protective cap from the scope of delivery or adhesive tape.
- e. **Do not expose the RAD HD battery pack to wet conditions.** Protect battery packs against moisture and do not immerse in liquids. This will cause damage to the RAD HD battery and increase the risk of electric shock. Contact with liquids can cause damage, which sometimes leads to heat generation, smoke, ignition or explosion of the battery pack sometimes hours or days after exposure.
- f. **Do not use faulty, damaged or deformed RAD HD batteries. Do not attempt to open the RAD HD battery. Do not short circuit the RAD HD battery.** Battery packs that show abnormal properties such as abnormal heating or poor power output, show signs of odor, heat, discoloration or thermal deformation should not be used. The use of defective or faulty battery packs can cause fire and explosion. Failure to comply will cause damage to the RAD HD battery and injury to the operator.
- g. **Do not expose battery packs or tools to fire or excessive heat.** Fire or temperatures above 130 ° C may cause the battery pack to ignite or explode. Failure to comply will cause damage to the RAD HD battery and injury to the operator.
- h. **If liquid is ejected from the RAD HD battery, avoid contact. If contact with skin occurs, immediately flush with water. If contact with eyes occurs, immediately flush with water and seek medical aid.** Liquid from the RAD HD battery may cause irritation and/or burns.
- i. **RAD HD battery packs cannot be disposed of with regular waste.** Dispose of RAD HD batteries according to local regulations or return RAD HD batteries to your RAD distributor.

Symbol Identification

These are symbols that can be found on the tool or in this manual and information about them.

	<p>Refer to instruction manual/booklet. This is used to signify that the instruction manual/booklet must be read.</p>
	<p>Do not expose battery packs to fire.</p>
	<p>Do not throw battery packs into the garbage.</p>
	<p>Protect battery packs from water and moisture.</p>

1.0 GENERAL INFORMATION

1.1 System Components

The B-RAD S Tool System is shipped in a storage case with the following parts:

- B-RAD S tool (Figure 1.1-1)
- Two RAD Li-ion battery packs (Figure 1.1-2)
- RAD battery charger (Figure 1.1-3)
- Standard reaction arm and snap ring (Figure 1.1-4)
- Calibration certificate
- User manual



Figure 1.1-1: B-RAD S



Figure 1.1-2: RAD Li-Ion Battery Pack



Figure 1.1-3: RAD Battery Charger



Figure 1.1-4: Standard Reaction Arm

1.2 Specifications

1.2.1 Tool Model Specifications

The following tables outline the torque ranges, weight, and vibration of the available B-RAD S models:

Tool Model	Torque Range (Imperial)	Torque Range (Metric)	Weight (includes battery)
B-RAD S 500 / 700-M	50-500 ft·lb	67-700 N·m	9.2 lb / 4.2 kg
B-RAD S 1000 / 1400-M	100-1000 ft·lb	135-1400 N·m	9.4 lb / 4.3 kg
B-RAD S 1500 / 2000-M	150-1500 ft·lb	200-2034 N·m	10.8 lb / 4.9 kg
B-RAD S 3000 / 4000-M	300-3000 ft·lb	400-4068 N·m	15.9 lb / 7.2 kg
B-RAD S 5000 / 7000-M	500-5000 ft·lb	678-7000 N·m	21.7 lb / 9.9 kg

Table 1.2.1-1: Tool Model Torque Ranges and Weights

Vibration (all tool models)	Does not exceed 2.5 m/s ²
Noise Level (all tool models)	85 ± 2 dB

Table 1.2.1-2: Tool Operation Specifications

1.2.2 Battery Specifications

Ensure that all battery specifications are followed when using the B-RAD S Tool System.

Battery Output	
Voltage	18 VDC
Current	100 A
Charge Time	60 minutes
Charger Voltage	
Input	115 or 230 VAC
Output	12 – 18 VDC
Charger Output Current	2.5 A

Table 1.2.2-1: Battery Specifications

1.2.3 Environmental Specifications



CAUTION!

Only operate the B-RAD S Tool System if the following storage and operation conditions have been met.

It is recommended that the operator wears hearing protection.

Warning!

The vibration emission during actual use of the power tool can differ from the declared total value depending on the ways in which the tool is used.

Identify safety measures to protect the operator that are based on an estimation of exposure in the actual conditions of use (taking into account all parts of the operating cycle such as the times when the tool is switched off and when it is running idle in addition to the trigger time).

Temperature Ranges	C	F
Operating Temperature	0 – 35	32 – 95
Charging Temperature	0 – 50	32 – 122
Storage Temperature	-25 – 70	-13 – 158
Humidity	10% to 90% non-condensing	
Shock	10G according to DIN IEC 68-2-6/29	
Vibration	1G, 10-150Hz according to DIN IEC 68-2-6/29	
Required Operating Conditions	Nonexplosive atmosphere Dry location	

Table 1.2.3-1: Environmental Specifications

1.2.4 Cycle of Operation

A cycle of operation or a tool cycle as used in this manual is defined as:

- 10 seconds on (forward or reverse)
- 10 seconds off

Note: An actual torque cycle may vary from the general definition above.

2.0 TOOL SYSTEM

The following sections introduce the operation of the tool handle, display interface, RAD Li-ion battery pack, and RAD battery charger.

2.1 Tool Handle

The B-RAD S (Figure 2.1-1) is activated with a trigger switch. The forward/reverse switch controls the direction of rotation. Torque values and tool information are displayed on the display module. Three buttons are used to enter the desired torque setting and view the menus. The RAD Li-ion battery pack is attached to the bottom of the tool handle. When the tool activates there will be a splash page, press the “RAD” button to initialize the tool.

1. Trigger switch – tool activation
2. Forward/reverse switch – controls direction of rotation: fully to the left is clockwise (forward); fully to the right is counterclockwise – CCW (reverse)
3. Display and **+** (Plus)/ **-** (Minus)/ “RAD” keypad
4. RAD Li-ion battery pack – refer to Section 2.3 – RAD Li-Ion Battery Pack
5. “Battery Release” button – refer to Section 2.3.1 – Insert/Remove the RAD Li-Ion Battery Pack



Figure 2.1-1: B-RAD S and Display

2.1.1 Trigger Lock

The trigger lock is useful while transporting or storing the B-RAD S. The trigger lock disables the use of the on/off trigger, therefore disabling the tool. It is suggested that while the B-RAD S is not in use, the trigger lock should be enabled.

To enable the trigger lock:

- Slide the forward/reverse switch to the centre position (neither fully to the right nor fully to the left).
Note: The on/off trigger cannot be pressed.

To disable the trigger lock:

- Slide the forward/reverse switch to the forward position or the reverse position.
Note: The on/off trigger can be pressed.

2.2 Display Interface



CAUTION!

The display module may be damaged by mechanical shock, electrostatic discharge, excessive force, moisture, or extreme temperatures. Avoid such conditions and gently wipe clean or let dry before use.

To turn on the display, attach the RAD Li-ion battery to the B-RAD S handle. There will be a splash screen that shows the current date, time, and name of the active log file. Press the “**RAD**” button momentarily to initialize the tool. The display will change to the torque select interface.

Note: If data logging is disabled then the screen will go directly to the torque select interface upon start-up.

The display goes into Sleep Mode and turns off after 30 seconds of inactivity while on the torque select interface. To turn it back on, lightly pull the trigger or press a button.

Note: The tool does not turn itself off while in any of the menus.

For more information, the interface is described in detail in Section 3.2 – Basic Level Functions and 3.3 – Advanced Level Functions.

2.2.1 Keypad

The keypad located below the display consists of three buttons used to navigate the B-RAD S interface (Figure 2.2.1-1).

- **+** (Plus, up, increase) button – used to increment numbers and navigate through menus.
- **-** (Minus, down, decrease) button – used to decrement numbers and navigate through menus.
- “**RAD**” (Menu, Enter, Select) button – used to select and toggle options, and enter various menus.

The “**RAD**” button has two different operations depending on how long it was pressed. From the Main Screen:

- A short press of the “**RAD**” button will highlight numbers on the screen in yellow, allowing the operator to modify the values (see section 3.2.1 – Change the Target Torque and 3.2. – Change the Target Angle).
- A long press will open the Main Menu.

Note: A long press is 3-5 seconds.



Figure 2.2.1-1: Display Interface

2.2.2 Key Lock

This function allows the buttons on the keypad to be locked. The user will not be able to open menus, select presets or change any values on the Main Screen.

To turn the key lock on:

Press and hold the "RAD" and **+** buttons until the key symbol appears in the top right corner of the screen as shown in Figure 2.2.2-1. The keypad is now locked.

To turn the key lock off:

Press and hold the "RAD" and **+** buttons until the key symbol disappears and the model number is once again shown. The keypad is now unlocked.



Figure 2.2.2-1: Key Lock Enabled

2.2.3 Main Screen

The Main Screen is the central interface for the B-RAD S Tool System. The target torque, torque units, target angle, B-RAD S model, program mode, and direction of rotation are displayed on the Main Screen. Figures 2.2.3-1 and 2.2.3-2 show the layout of the Main Screen.



Figure 2.2.3-1: Main Screen – Torque



Figure 2.2.3-2: Main Screen – Program Mode

2.3 RAD Li-Ion Battery Pack



CAUTION!

Only use the RAD Li-ion battery pack with the B-RAD S Tool System. Using third-party batteries may damage the B-RAD S Tool System.

Keep the RAD Li-ion battery pack away from any metal objects. If the battery terminals are connected by a metal object, the battery will short and cause damage to the battery and injury to the operator.

The RAD Li-ion battery pack supplies power to the tool; for the B-RAD S to perform best, ensure the RAD battery is fully charged and in good condition before use. In optimal conditions, the RAD battery should be capable of approximately 100 torque cycles at 50% of the maximum torque.

Note: The application torque, joint hardness, battery condition, age, and operating temperature will affect the actual number of torque cycles per charge.

2.3.1 Insert/Remove the RAD Li-Ion Battery Pack

To insert the RAD battery:

1. Ensure the on/off trigger is in the off position (not depressed).
2. Align the RAD battery with the bottom of the tool handle.
3. Slide the RAD battery into place until it is fully seated.
Note: A click will confirm that the RAD battery is locked in place.
4. Check that the RAD battery is locked in place by trying to slide it out of place.

To remove the RAD battery:

1. Press and hold the **"Battery Release"** button. See Section 2.1 – Tool Handle for photo reference.
2. Slide the RAD battery away from the tool handle.

2.3.2 Check RAD Battery Charge

To check the RAD battery charge:

- Press the **"Charge"** button on the RAD battery (Figure 2.3.2-1).

Result: The green bars will light up. If all the bars are illuminated, the battery is fully charged. If only one of the bars is illuminated, the RAD battery is discharged and needs charging (refer to Section 2.4.1 – Charging the RAD Li-Ion Battery Pack).

- Battery voltage may also be viewed on the B-RAD S display from the Information Menu. See Section 3.2.9 – Information.

Note: When the battery charge gets too low, the "batterie empty" will be displayed on the screen.



Figure 2.3.2-1: RAD Li-Ion Battery Pack

2.4 RAD Battery Charger



CAUTION!

The RAD Li-ion battery pack should only be charged on the RAD battery charger. If an incompatible charger is used, damage to the RAD battery will occur.

The charging status display (Figure 2.4-1) indicates when the RAD battery is charging, when the charge is complete, and if there is an error.

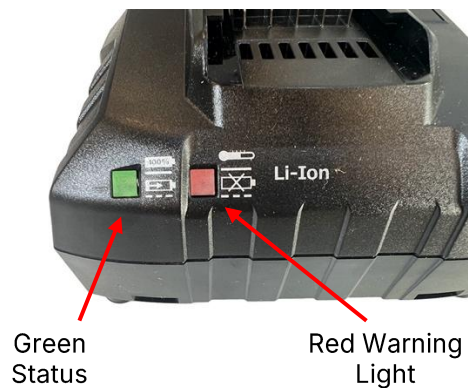

Figure 2.4-1: Charging Status Display

2.4.1 Charging the RAD Li-Ion Battery Pack

Note: The temperature range for charging is 0°C to 50°C (32 °F to 122 °F).

To charge the RAD battery:

1. Plug the RAD battery charger into the wall outlet. The red warning light will turn on for one second and then the green status light will turn on for one second.
2. Align the RAD battery with the RAD battery charger.
3. Slide the RAD battery into place. The green status light will flash while the RAD battery is charging.

When the RAD battery has been fully charged, the green status light will stop flashing and stay illuminated. Until the RAD battery is removed from the RAD charger, the charger will maintain the battery charge at maximum capacity.

To remove the RAD battery:

1. Slide the RAD battery away from the RAD charger.
2. Check that the RAD battery is fully charged (refer to Section 2.3.2 – Check RAD Battery Charge).

2.4.2 Charging Errors

The red warning light is on:

The RAD battery is not charging because its temperature is not within the required temperature range for charging. When the RAD battery's temperature changes to within the required range, the red warning light will turn off and charging will commence.

The red warning light is flashing:

The RAD battery may be placed incorrectly on the RAD battery charger. Remove the RAD battery and replace it correctly on the RAD battery charger. If the red warning light continues to flash, the RAD battery is defective; remove the RAD battery immediately.

If these problems continue, contact New World Technologies Inc. Technical Support (refer to Section 8.0 – Contact Us) or your RAD distributor.

3.0 B-RAD S FUNCTIONS

The B-RAD S controller and display are used to set up the tool and change settings. The display interface has many functions, including Presets, torque settings, and calibration. The following sections describe these functions as well as how to enable and use them.

Refer to Section 2.2 – Display Interface to understand the use of the buttons in this section.

3.1 Unlock Levels

Access to the functions on the display has been restricted to three access levels: the Basic level, the Intermediate level and the Advanced level. Access to the Intermediate and Advanced levels requires a password. Each level has access to different functions. Table 3.1-1 outlines the functions accessible in each level.

Function	Level		
	Basic	Intermediate	Advanced
Norm-Program/Check-Program Selection	✓	✓	✓
View Log Files	✓	✓	✓
Select Tool Presets	✓	✓	✓
View Statistics	✓	✓	✓
View Tool Information and Serial Number	✓	✓	✓
View Tool System Diagnostics	✓	✓	✓
Set Torque Values	✓	✓	✓
Set Angle Values	✓	✓	✓
Reset Maintenance Counter	✗	✓	✓
Point Calibration	✗	✓	✓
Change Torque Units	✗	✓	✓
Change Interface Language	✗	✓	✓
Set Back-off Values	✗	✓	✓
Set Tool Presets	✗	✓	✓
Calibration	✗	✗	✓

Table 3.1-1: User Access Levels and Functions

3.1.1 Unlocking Access Levels

Access Level	Passcode
Basic	No Code Needed
Intermediate	17580
Advanced	Contact your RAD distributor

Table 3.1.1-1: Access Levels and Passwords

To unlock an access level:



1. Press and hold the "RAD" button to open the Main Menu (Figure 3.1.1-1).
2. Press the  button to highlight the "Extended" option.
3. Press the "RAD" button. The Password Input Screen will be displayed (Figure 3.1.1-2).
4. Use the navigation keypad to enter the desired password (See Table 3.1.1-1).
Note: Use the  and  buttons to select a number. Use the "RAD" button to accept the number and move to the next character.
5. Once the "OK" is highlighted on the display, press the "RAD" button to enter the password.
6. The Main Menu will be displayed again.
7. Select the "Extended" option again, which enters the Extended Menu (Figure 3.1.1-3).



Figure 3.1.1-1: Main Menu



Figure 3.1.1-2: Password Input Screen



Figure 3.1.1-3: Extended Menu Screen

3.1.2 Returning to the Basic Level

The B-RAD S will revert to the Basic level every time power is removed from the tool.

To return to the Basic access level while tool is powered:

1. Press and hold the "RAD" button to open the Main Menu (Figure 3.1.2-1).
2. Press the navigation keypad to highlight the "Extended" option.
3. Press the "RAD" button to get to the Extended Menu Screen (Figure 3.1.2-2).
4. Use the navigation keypad to select the "Lock" option.
5. The Main Menu will be displayed and the B-RAD S will be in the Basic access level.

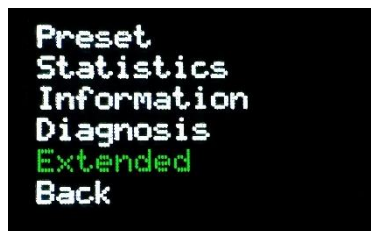

Figure 3.1.2-1: Main Menu



Figure 3.1.2-2: Extended Menu Screen

3.2 Basic Level Functions

The following sections describe the functions available when the B-RAD S is in the Basic level. Refer to Section 3.1 – Unlock Levels for more information on the accessibility of these functions.

3.2.1 Change the Target Torque

The target torque is the torque output at which the B-RAD S will stop the torque cycle and the cycle will be considered a pass. For more information on the target torque and torque cycle, refer to Section 4.2 – Torque Operation.

Note: Refer to Section 1.2.1 – Tool Model Specifications for more information.

To change the target torque:

1. Press the **"RAD"** button briefly to highlight the target torque value in yellow (Figure 3.2.2-1).

Note: Each button press will toggle between torque, angle (if enabled), and no highlight.

2. Use the **+** button to increase the target torque or the **-** button to decrease the target torque.

Note: While either the **+** button or the **-** button is continuously pressed:

- i. The torque value will increase or decrease by one unit at a time while the button is being pressed.
 - ii. Once the torque value has changed at least 10 units, it will begin to change by 10 units at a time.
 - iii. After the torque value has changed at least 100 units, it will begin to change by 100 units at a time.
3. Once the desired target torque is displayed, press the **"RAD"** button to deselect the torque value and again to deselect the angle (if enabled). The B-RAD S is ready for a torque cycle.



Figure 3.2.2-1: Main Menu – Torque Selected

3.2.2 Change the Target Angle

This function allows for changing the target angle. The target angle is the rotation angle, in degrees, that the B-RAD S will move after the target torque (pre-torque) is reached. For more information on target angle and torque and angle operation, refer to Section 4.3 – Torque and Angle Operation.

Note: The final torque of a torque and angle cycle will not exceed the set angle torque limit of the tool.

To change the target angle:

1. Press the **"RAD"** button briefly until the target angle value on the Main Screen is highlighted (Figure 3.2.2-1).

Note: The **"RAD"** button will toggle the highlight through torque, angle, and no highlight.

2. Use the **+** button to increase the angle value or use the **-** button to decrease the angle value.

Note: The maximum angle value is 360°.

3. Once the desired angle is set, press the **"RAD"** button to deselect the angle value. The B-RAD S is ready for a torque and angle cycle.



Figure 3.2.2-1: Main Menu – Angle Selected

3.2.3 Select Preset – Customerpreset

The B-RAD S can save up to twenty user defined Presets.

To select a Preset:

1. While on the Main Screen, press and hold the “RAD” button to open the Main Menu (Figure 3.2.3-1).
2. The “Preset” option will be highlighted. Press the “RAD” button.
3. The Preset Menu will be displayed with the “Customerpreset” highlighted (Figure 3.2.3-2). Press the “RAD” button.
4. The Preset Details Screen will be displayed (Figure 3.2.3-3):
 - Preset number and user defined name
 - Torque / torque units / angle
 - Lower-upper limits
 - Bolt cycles allowable
 - Note:** 0 signifies there is no limit set.
 - Norm or Check Programme Mode.
 - Back-off angle (B)
5. Use the navigation buttons to go through the saved Presets.
6. When on the Preset with the desired values press the “RAD” button to open the “Preset Options” (Figure 3.2.3-4).
7. Highlight “Accept” and press the “RAD” button to accept the Preset. The tool will return to the Main Screen.



Figure 3.2.3-1: Main Menu



Figure 3.2.3-2: Preset Menu

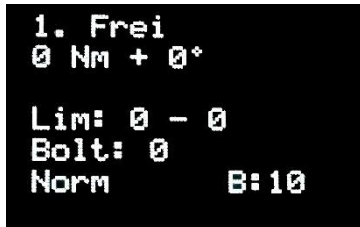

Figure 3.2.3-3: Preset Details Screen



Figure 3.2.3-4: Preset Options

Caution: The torque units the B-RAD S uses will change to those saved in the Preset if they are different.

3.2.4 Select Preset – HV-Preset

HV-Presets can only be selected and not overwritten.

To select a Preset:

1. While on the Main Screen, press and hold the “RAD” button to open the Main Menu (Figure 3.2.4-1).
2. The “Preset” option will be highlighted. Press the “RAD” button.
3. The Preset Menu will be displayed (Figure 3.2.4-2). Navigate to “HV-Preset” and press the “RAD” button.

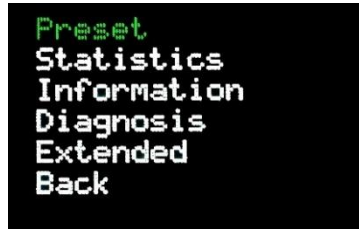

Figure 3.2.4-1: Main Menu



Figure 3.2.4-2: Preset Menu

4. The Preset Details Screen will be displayed (Figure 3.2.4-3):
 - Preset name
 - Torque / torque units / angle
 - Lower-upper limits
 - Bolt cycles allowable
 - Note:** 0 signifies there is no limit set.
 - Norm or Check Programme Mode.

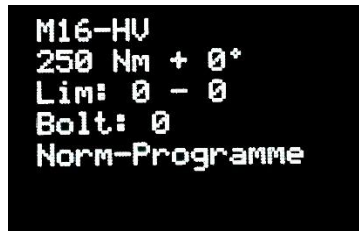

Figure 3.2.4-3: HV-Preset Details Screen



Figure 3.2.4-4: HV-Preset Options

5. Use the navigation buttons to go through the HV-Presets.
6. When on the HV-Preset with the desired values press the “RAD” button to open the “Preset Options” (Figure 3.2.4-4).
7. Highlight “Accept” and press the “RAD” button to accept Preset. The tool will return to the Main Screen.

Caution: The torque units the B-RAD S uses will change to those saved in the Preset if they are different.

3.2.5 Norm-Program Mode

The Norm-Program Mode is used when performing a standard torque or torque and angle cycle.

To switch to Norm-Program Mode:

1. While on the Main Screen, press and hold both the **+** and **-** buttons until the Data Logging Menu opens (Figure 3.2.5-1).

Note: Menu will appear after 3 seconds.

2. With “Prog.Selection” highlighted, press the “RAD” button.
3. With “Norm-Programme” highlighted, press the “RAD” button (Figure 3.2.5-2).

Note: A checkmark beside the name indicates which program is active.

4. Navigate to “Back” and press the “RAD” button to exit.



Figure 3.2.5-1: Data Logging Menu



Figure 3.2.5-2: Program Selection Menu – Norm-Program



Figure 3.2.5-3: Main Screen – Norm-Program Mode

3.2.6 Check-Program Mode

The Check-Program Mode is used when wanting to check the torque on an already tightened bolt. Check-Program Mode slows the speed of the drill so that it doesn't tighten an already tightened bolt during the time it takes to measure the current torque. The angle that is shown on the screen is the angle the tool has moved to reach the set torque. If the angle shown is 0, or a small angle, the bolt has been tightened to at least the set torque. It may be used with Limits enabled to create a pass/fail function (see Section 3.3.3 Settings – Limits). A torque and angle cycle is not available in this mode.

To switch to Check-Program Mode:

1. While on the Main Screen, press and hold both the **+** and **-** buttons for 3 seconds to open the Data Logging Menu (Figure 3.2.6-1).
2. With "Prog.Selection" highlighted, press the "RAD" button.
3. With "Check-Programm" highlighted, press the "RAD" button (Figure 3.2.6-2).
Note: A checkmark beside the name indicates which program is active.
4. Navigate to "Back" and press the "RAD" button to exit.



Figure 3.2.6-1: Data Logging Menu

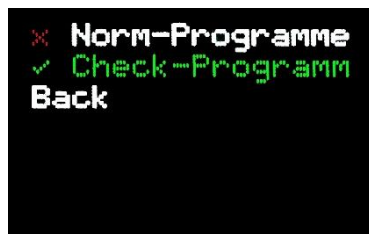

Figure 3.2.6-2: Program Selection Menu – Check-Program



Figure 3.2.6-3: Check-Program Main Screen

3.2.7 View Log File

Every time the B-RAD S completes a cycle it creates a log file that holds information related to the cycle.

To select and view a log file:

1. While on the Main Screen, press and hold both the **+** and **-** buttons for 3 seconds to open the Data Logging Menu (Figure 3.2.7-1).
2. With "View Log File" highlighted, press the "RAD" button.
3. View individual cycle records using the navigation buttons (Figure 3.2.7-2). The information shown includes ID: sequential number/ operation number, date and time, T: set torque / final torque, Unit: torque units, and A: set angle / final angle
4. To view more information on a log file, hold the **+** or **-** button for 2 seconds to switch between the first and second information pages (Figure 3.2.7-3). The information shown includes TotM: Final torque with angle tightening, Lim: Set limits, Mov: Angle moved / cycle time, Sup: Battery voltage, Prog.: Mode the program was in during cycle, and Wk: Operator.
5. Press "RAD" button to exit back to Data Logging Menu.



Figure 3.2.7-1: Data Logging Menu

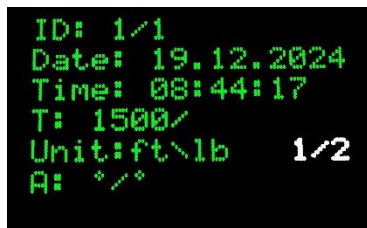

Figure 3.2.7-2: View Log File – Page 1

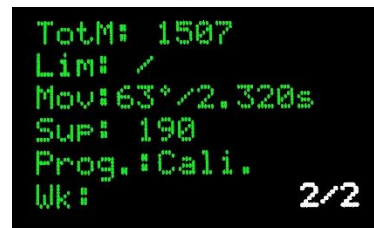

Figure 3.2.7-3: View Log File – Page 2

3.2.8 Statistics – Cycle Counts

The Statistics Menu contains the cycle counts for the tool.

Maint.-Counter: This is the maintenance life cycle counts for the tool which is used to track how many cycles the tool was used for since its last service. This cycle counter can be cleared under Advanced unlock level (see Section 3.3.12 – Maintenance – Delete Maintenance Cycles).

Total-Counter: This is the total life cycle counts for the tool which is used to track how many cycles the tool was used for since it was first made. This cycle counter can not be cleared.

To view the cycle counts:

1. Press and hold the “RAD” button until the Main Menu opens (Figure 3.2.8-1).
2. With “Statistics” highlighted, press the “RAD” button.
3. Use the navigation buttons to switch between viewing “Maint.-Counter” (Figure 3.2.8-2) and “Total-Counter” (Figure 3.2.8-3).
 - They will show the torque cycles performed between 0-20% of power, 21-80% of power, 81-100% of power and, the total number of cycles performed.
4. Press “RAD” button to exit back to Main Menu.

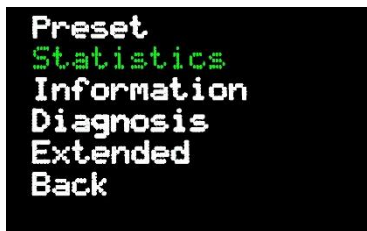

Figure 3.2.8-1: Main Menu

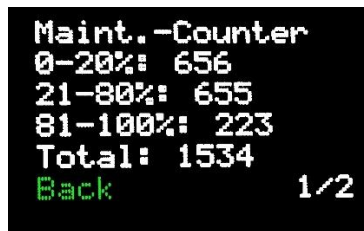

Figure 3.2.8-2: Maintenance Life Cycle Counts

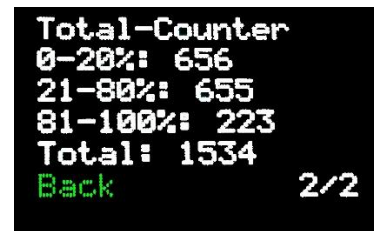

Figure 3.2.8-3: Total Life Cycle Counts

3.2.9 Information

The Information Menu contains the program version, tool serial number, and customer service contact information.

To view the tool information:

1. Press and hold the “RAD” button until the Main Menu opens (Figure 3.2.9-1).
2. With “Information” highlighted, press the “RAD” button.
3. Information Screen (Figure 3.2.9-2):
 - Ver: - Program version
 - S.No.: - Tool serial number
 - Customer service contact information
4. Press “RAD” button to exit back to Main Menu.



Figure 3.2.9-1: Main Screen



Figure 3.2.9-2: Information Menu

3.2.10 Diagnosis

The Diagnosis Menu contains information on the general status of the B-RAD S tool.

To view the diagnosis information:

1. Press and hold the "RAD" button until the Main Menu opens (Figure 3.2.10-1).
2. With "Diagnosis" highlighted, press the "RAD" button.
3. Use the navigation buttons to switch between page 1 (Figure 3.2.10-2) and page 2 (Figure 3.2.10-3).
Note: When Status reaches 100% the drill should be maintained.
4. Press "RAD" button to exit back to Main Menu.

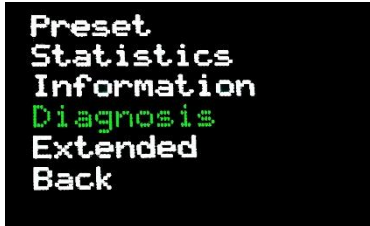

Figure 3.2.10-1: Main Menu



Figure 3.2.10-2: Diagnosis Page 1

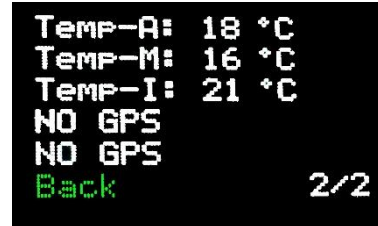

Figure 3.2.10-3: Diagnosis Page 2

3.3 Advanced Level Functions

The following sections describe the functions available when the B-RAD S is in the Advanced level. Refer to Section 3.1 – Unlock Levels for more information on the accessibility of these functions.

Note: Make sure the B-RAD S is unlocked in the Advanced level before proceeding.

3.3.1 Save Preset – Customerpreset

The B-RAD S can save up to twenty user defined Presets.

To save a Customerpreset:

1. Set all desired settings for the Preset.
2. Press and hold the “RAD” button to open the Main Menu (Figure 3.3.1-1).
3. The “Preset” option will be highlighted. Press the “RAD” button.
4. The Preset Menu will be displayed with the “Customerpreset” highlighted (Figure 3.3.1-2). Press the “RAD” button.
5. The Preset Details Screen will be displayed (Figure 3.3.1-3).
6. Use the navigation buttons to go through the saved Presets.
7. When on the Preset to be overwritten press the “RAD” button to open the “Preset Options” (Figure 3.3.1-4).
8. Highlight “Overwrite” and press the “RAD” button to overwrite that Preset.
9. On the Preset Name Save Screen (Figure 3.3.1-5) that comes up, a desired name for the Preset can be entered.
10. Use the **+** and **-** buttons to change the highlighted digit.
11. Use the “RAD” button to accept the digit and advance to the next.
12. Once “Save” is highlighted, press the “RAD” button to save and exit back to Preset Details Screen (Figure 3.3.1-6).

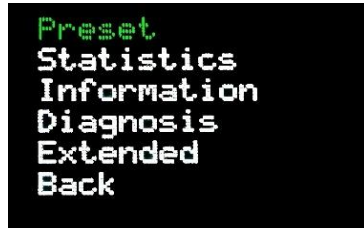

Figure 3.3.1-1: Main Menu



Figure 3.3.1-2: Preset Menu



Figure 3.3.1-3: Preset Details Screen



Figure 3.3.1-4: Preset Options



Figure 3.3.1-5: Preset Name Save Screen

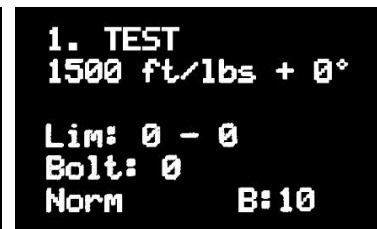

Figure 3.3.1-6: Preset Details Screen

3.3.2 Settings – Angle Enable/Disable

This option is available if it is desired to enable/disable the angle option from being available on the Torque Select Screen.

Note: This option comes *enabled* from factory.

To enable/disable Angle Mode:

1. Press and hold the "RAD" button to enter the Main Menu (Figure 3.3.2-1).
2. Select "Extended" and input the password to enter the Extended Menu (Figure 3.3.2-2).
3. Select "Settings" to enter the Settings Menu (Figure 3.3.2-3).
4. Select "Angle". The Angle is enabled when there is a green checkmark beside it. Figure 3.3.2-4 shows the Main Screen with Angle Mode enabled.

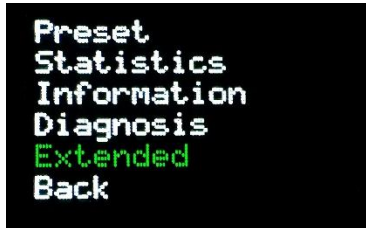

Figure 3.3.2-1: Main Menu



Figure 3.3.2-2: Extended Menu

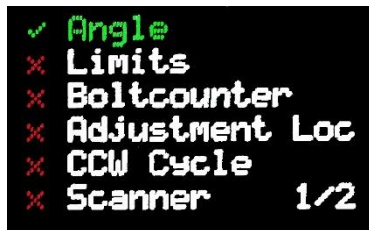

Figure 3.3.2-3: Settings Menu



Figure 3.3.2-4: Main Screen with Angle Enabled

3.3.3 Settings – Limits

Enabling this option allows the for limits to be placed on a torque setting. Cycles that fall outside of the set limits will result in a failed cycle.

Note: This option comes *disabled* from factory.

To enable limits:

1. Press and hold the “RAD” button to enter the Main Menu (Figure 3.3.3-1).
2. Select “Extended” and input the password to enter the Extended Menu (Figure 3.3.3-2).
3. Select “Settings” to enter the Settings Menu (Figure 3.3.3-3).
4. Select “Limits”. The Limits are enabled when there is a green checkmark beside it.

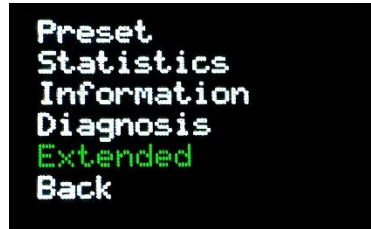

Figure 3.3.3-1: Main Menu



Figure 3.3.3-2: Extended Menu

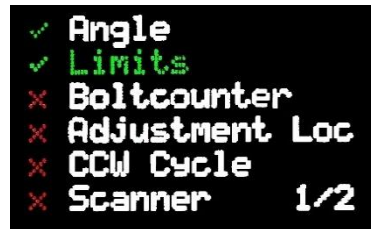

Figure 3.3.3-3: Settings Menu



Figure 3.3.3-4: Torque Selected

To set limits:

1. While on the Main Screen, press the “RAD” button to highlight the torque (Figure 3.3.3-4). Continue pressing the “RAD” button until the Lower Limit Screen appears (Figure 3.3.3-5).
2. Use the + and - to adjust the lower limit to the desired value.
3. Press the “RAD” button to advance to the Upper Limit Screen. Use the + and - to adjust the lower limit to the desired value (Figure 3.3.3-6).
4. Press the “RAD” button to advance to the Tolerance Screen. Use the + and - to adjust the lower limit to the desired value (Figure 3.3.3-7).
5. Press the “RAD” button to save and return to the Main Screen.



Figure 3.3.3-5: Lower Limit Screen



Figure 3.3.3-6: Upper Limit Screen



Figure 3.3.3-7: Tolerance Screen

Note: For more information contact your RAD distributor for assistance.

3.3.4 Settings – Bolt Counter

Enabling this option allows a cycle counter to be input that will disable the tool once that amount is reached. The Bolt Counter counts all completed cycles in the clockwise direction. Once the tool is locked there are two ways to unlock the tool: resetting the Bolt Counter or disabling the Bolt Counter. To avoid bolts being retightened and increasing the bolt count, angle limits can be used with Bolt Counter.

Note: This option comes *disabled* from factory.

To enable Bolt Counter:

1. Press and hold the "RAD" button to enter the Main Menu (Figure 3.3.4-1).
2. Select "Extended" and input the password to enter the Extended Menu (Figure 3.3.4-2).
3. Select "Settings" to enter the Settings Menu (Figure 3.3.4-3).
4. Select "Bolt Counter". The Bolt Counter is enabled when there is a green checkmark beside it.



Figure 3.3.4-1: Main Menu



Figure 3.3.4-2: Extended Menu

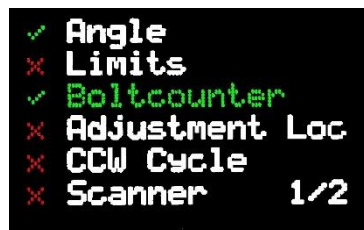

Figure 3.3.4-3: Settings Menu



Figure 3.3.4-4: Torque Selected

To set Bolt Counter:

1. While on the Main Screen, press the "RAD" button to highlight the torque (Figure 3.3.4-4). Continue pressing the "RAD" button until the Bolt Counter Screen opens. (Figure 3.3.4-5).
2. Use the + and - to adjust the bolt count to the desired value.



Figure 3.3.4-5: Bolt Counter Screen



Figure 3.3.4-6: Program Mode Main Screen with Bolt Counter

Note: The Bolt Counter can be set between 1-999.

3. Press the "RAD" button to save and return to the Main Screen. The Bolt Counter will be shown on the Main Screen (Figure 3.3.4-6).

Note: For more information contact your RAD distributor for assistance.

3.3.5 Settings – Adjustment Lock

Enabling the Adjustment Lock allows the changing of torque values to be disabled in the Basic level. With Adjustment Lock enabled while in Basic level, Presets must be used to change the torque.

Note: This option comes *disabled* from factory.

To enable Adjustment Lock:

1. Press and hold the "RAD" button to enter the Main Menu (Figure 3.3.5-1).
2. Select "Extended" and input the password to enter the Extended Menu.
3. Select "Settings" to enter the Settings Menu (Figure 3.3.5-2).
4. Select "Adjustment Lock". The Adjustment Lock is enabled when there is a green checkmark beside it as in Figure 3.3.5-3.

Note: For more information contact your RAD distributor for assistance.

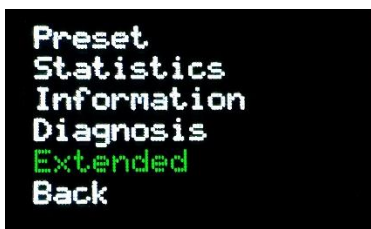

Figure 3.3.5-1: Main Menu



Figure 3.3.5-2: Extended Menu

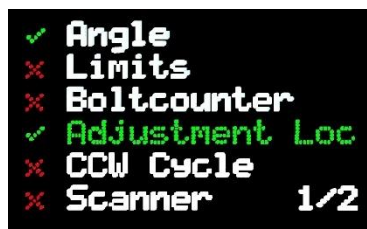

Figure 3.3.5-3: Settings Menu

3.3.6 Settings – Counterclockwise (CCW) Cycle

Enabling CCW Cycle allows the torque wrench to perform cycles in the counterclockwise direction. This is useful for applications that require a defined loosening of a bolted connection or require a tightening of a counterclockwise threaded bolt.

Note: This option comes *disabled* from factory.

To enable CCW Cycle:

1. Press and hold the "RAD" button to enter the Main Menu (Figure 3.3.6-1).
2. Select "Extended" and input the password to enter the Extended Menu.
3. Select "Settings" to enter the Settings Menu (Figure 3.3.6-2).
4. Select "CCW Cycle". The Counterclockwise Cycle is enabled when there is a green checkmark beside it as in Figure 3.3.6-3.

Note: For more information contact your RAD distributor for assistance.



Figure 3.3.6-1: Main Menu



Figure 3.3.6-2: Extended Menu



Figure 3.3.6-3: Settings Menu

3.3.7 Settings – Torque Sensor Enable/Disable

 **CAUTION!** Disabling this feature has effects on the function and accuracy of the electric torque wrench.

In the case where the sensor is causing issues and the tool still needs to be used, the sensor can be disabled.

Note: This option comes *enabled* from factory.

To disable the torque sensor:

1. Press and hold the "RAD" button to enter the Main Menu (Figure 3.3.7-1).
2. Select "Extended" and input the password to enter the Extended Menu.
3. Select "Settings" to enter the Settings Menu (Figure 3.3.7-2).
4. Select "Torquesensor". The torque sensor is disabled when there is a red "X" beside it as in Figure 3.3.7-3.

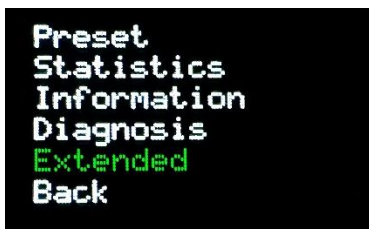

Figure 3.3.7-1: Main Menu



Figure 3.3.7-2: Extended Menu



Figure 3.3.7-3: Settings Menu

Note: For more information contact your RAD distributor for assistance.

3.3.8 Settings – Point Calibration Setup

Point Calibration is a function which allows a single torque point to be fine-tuned to suit the needs of an application. A Point Calibration can be saved as a Preset (see Section 3.3.1 Save Preset – Customerpreset).

If Point Calibration is enabled on a torque and angle cycle, the point calibration will affect the pre-torque value.

Note: This function should only be used when the sensor is disabled.

Note: Point Calibration does not replace the tool calibration. For information on tool calibration, refer to Section 5 – Calibration. A full calibration must be done before Point Calibration may be used.

To enable or disable Point Calibration:

1. Change the torque to the desired value.

Note: Refer to the following sections to set the torque: Section 3.2.1 Change the Target Torque.



Figure 3.3.8-1: Settings Menu



Figure 3.3.8-2: Bolt 1 Torquing Screen

2. Go to: Main Menu > Extended > Settings > Pointcali (Figure 3.3.8-1).

3. Perform a torque cycle on a test bench for "Bolt 1" (Figure 3.3.8-2).

4. Press the "RAD" button to highlight the number in yellow and adjust it to match the torque displayed by the test bench.



Figure 3.3.8-3: Bolt 2 Torquing Screen



Figure 3.3.8-4: Point Calibration Save Screen

5. Press "RAD" button to accept changes.

6. Use the navigation buttons to go to "Bolt 2" (Figure 3.3.8-3) and perform another torque cycle on the test bench.

7. Press the "RAD" button to highlight the number in yellow and adjust it to match the torque displayed by the test bench.



Figure 3.3.8-5: Point Calibration Abort Screen



Figure 3.3.8-6: Main Screen – Point Calibration Enabled

8. Press "RAD" button to accept changes.

9. Use the navigation buttons to go to the "Save" page (Figure 3.3.8-4) and press the "RAD" button to save the Point Calibration and exit to the Settings Menu.

Note: Go to the "Abort" page and press the "RAD" button to discard the changes and exit (Figure 3.3.8-5).

10. Exit back to the Main Screen to use the point calibrated torque setting which is indicated by the bullseye symbol in the top right corner of the display (Figure 3.3.8-6).

3.3.9 Settings – Unit Selection

The options for units are imperial (ft·lb), metric (N·m), and 100 steps.

To change the torque units:

1. Hold the “RAD” button to enter to the Main Menu (Figure 3.3.9-1).
2. Select “Extended” and enter the password. Select “Extended” again to enter the Extended Menu (Figure 3.3.9-2).
3. Select “Settings”.
4. Select “Unit” from the second page (Figure 3.3.9-3).
5. Navigate to the desired units and press “RAD” button to accept (Figure 3.3.9-4).



Figure 3.3.9-1: Main Menu



Figure 3.3.9-2: Extended Menu



Figure 3.3.9-3: Settings Menu – Page 2



Figure 3.3.9-4: Unit Menu

Note: For more information on the 100 steps option please contact your RAD distributor for assistance.

3.3.10 Settings – Language Selection

The following language options are available:

- English
- German
- Spanish
- French
- Dutch

To change the language:

1. Hold the “RAD” button to enter to the Main Menu (Figure 3.3.10-1).
2. Select “Extended” and enter the password. Select “Extended” again to enter the Extended Menu (Figure 3.3.10-2).
3. Select “Settings”.
4. Select “Language” from the second page (Figure 3.3.10-3).
5. Navigate to the desired language and press “RAD” button to accept (Figure 3.3.10-4).



Figure 3.3.10-1: Main Menu



Figure 3.3.10-2: Extended Menu



Figure 3.3.10-3: Settings Menu – Page 2



Figure 3.3.10-4: Language Menu

3.3.11 Settings – Back-off Setup

The amount the B-RAD S backs off after it finishes a cycle is adjustable.

Note: Trigger must remain depressed after the completion of a cycle until it comes to a complete stop for back-off to complete.

To change the back-off angle:

1. Hold the "RAD" button to enter to the Main Menu (Figure 3.3.11-1).
2. Select "Extended" and enter the password. Select "Extended" again to enter the Extended Menu (Figure 3.3.11-2).
3. Select "Settings".
4. Select "Backoff" from the second page (Figure 3.3.11-3).
5. Press the "RAD" to select the angle value. Using the + and - buttons to adjust the value (Figure 3.3.11-4).
6. Press the "RAD" to deselect the angle value.
7. Use the + or - buttons to navigate to the Save Screen and press the "RAD" button to save the value (Figure 3.3.11-5).

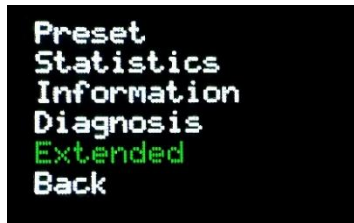

Figure 3.3.11-1: Main Menu



Figure 3.3.11-2: Extended Menu



Figure 3.3.11-3: Settings Menu



Figure 3.3.11-4: Back-Off Screen



Figure 3.3.11-5: Back-Off Save Screen

Note: The default from factory is 10 degrees.

3.3.12 Maintenance – Delete Maintenance Cycles

The maintenance life cycle counts for the tool are used to track the usage cycles of the tool since its last service. These can be cleared after the tool is serviced to better track its usage after any service work is done on the tool.

To delete the maintenance cycles:

1. Hold the "RAD" button to enter to the Main Menu (Figure 3.3.12-1).
2. Select "Extended" and enter the password. Select "Extended" again to enter the Extended Menu (Figure 3.3.12-2).
3. Select "Maintenance".
4. Select "Delete Maint" to delete the maintenance life cycles (Figure 3.3.12-3).

Note: For more information contact your RAD distributor for assistance.

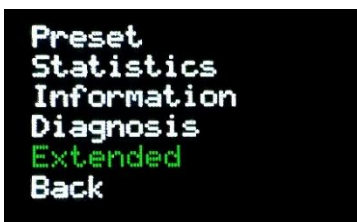

Figure 3.3.12-1: Main Menu



Figure 3.3.12-2: Extended Menu



Figure 3.3.12-3: Maintenance Menu

3.3.13 Data Logging – Choose Log File

This function allows the user to set up a name for the log files.

To choose a log file:

1. Press and hold the **+** and **-** buttons until the Data Logging Menu opens as in Figure 3.3.14-1.
2. Select "Choose Log File".
3. On the screen that comes up, a desired name for the log file can be entered (Figure 3.3.13-2).
4. Use the **+** and **-** buttons to change the highlighted digit.
5. Use the "RAD" button to accept the digit and advance to the next.
6. Once "Save" is highlighted, press the "RAD" button to save and exit.

Note: For more information contact your RAD distributor for assistance.



Figure 3.3.13-1: Data Logging Menu

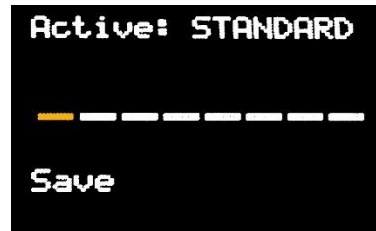

Figure 3.3.13-4: Log File Input Screen

3.3.14 Data Logging – Date/Time Setup

Allows the user to set or change the date/time.

To change/set the date and time:

1. Press and hold the **+** and **-** buttons until the Data Logging Menu opens as in Figure 3.3.14-1.
2. Select "Date/Time".
3. On the Date/Time Screen (Figure 3.3.14-2) that comes up, the date and time can be adjusted if needed.
4. Press the **+** or **-** button once to highlight the date digit.
5. Then use the **+** and **-** buttons change the highlighted digit to the desired value (DD/MM/YYYY).
6. Use the "RAD" button to accept the digit and advance to the next digit and change as needed.
7. Once "Save" is highlighted, press the "RAD" button to save and exit.

Note: For more information contact your RAD distributor for assistance.



Figure 3.3.14-1: Data Logging Menu



Figure 3.3.14-2: Date/Time Screen

3.3.15 Data Logging – Settings – Worker-ID

Enabling this option makes it so that users have a worker ID that is saved in the logs for tracking who was using the tool during a cycle.

To enable Worker-ID:

1. Press and hold the **+** and **-** buttons until the Data Logging Menu opens as in Figure 3.3.15-1.
2. Select "Settings" to open the Data Logging Settings Menu.
3. Select "Worker-ID" to toggle the function on and off. The Worker-ID is on when there is a green checkmark beside Worker-ID as in Figure 3.3.15-2.

- When the function is first turned on and when the tool is turned on anytime after Worker-ID is on, the Worker-ID Input Screen will appear as in Figure 3.3.15-3 for the user to input their name.
Note: Worker IDs may be between 1-9 characters.

Note: For more information contact your RAD distributor for assistance.



Figure 3.3.15-1: Data Logging Menu

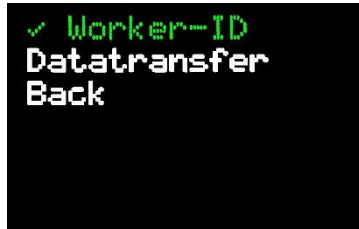

Figure 3.3.15-2: Data Logging Settings Menu

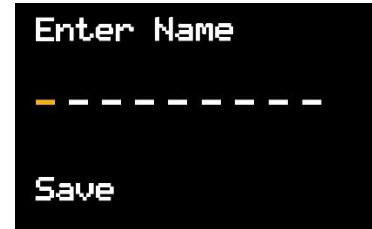

Figure 3.3.15-3: Worker-ID Input Screen

3.3.16 Data Logging – Settings – Data Transfer

When the logs need to be downloaded the tool must be put into Data Transfer Mode to allow for the transfer.

To put the tool into Data Transfer Mode:

- Press and hold the **+** and **-** buttons until the Data Logging Menu opens as in Figure 3.3.16-1.
- Select "Settings".
- In Data Logging Settings, select "Datatransfer" (Figure 3.3.16-2) to enter Data Transfer Mode (Figure 3.3.16-3).

Note: For more information contact your RAD distributor for assistance.



Figure 3.3.16-1: Data Logging Menu



Figure 3.3.16-2: Data Logging Settings Menu



Figure 3.3.16-3: Data Transfer Screen

4.0 GENERAL OPERATING INSTRUCTIONS



CAUTION!

Only qualified personnel with training in the safe operation of torque tooling and the B-RAD S Tool System should operate this tool. Refer to the Important Safety Notice for more information.

The B-RAD S has two operating modes: Torque Only Mode or Torque and Angle Mode. The torque only cycle passes when the actual torque reaches the target torque, and the cycle fails if it is interrupted before the actual torque reaches the target torque. The torque and angle cycle passes when the angle after the pre-torque reaches the target angle and fails if it is interrupted before the target angle is reached, torque exceeds the maximum torque for the tool, or the limits are exceeded if set (see Section 3.3.3 Settings – Limits).

This section instructs the operator in the use of the reaction arm and how to conduct a torque only or a torque and angle cycle.

4.1 Reaction Arm



WARNING!

Always keep body parts clear of the reaction arm when the B-RAD S Tool System is in use. Serious injury could occur.

CAUTION!

Ensure that the reaction arm has a solid contact point before operating the B-RAD S Tool System.

Improper reaction will void warranty and can cause premature tool failure.

Please contact New World Technologies Inc. or your local RAD authorized distributor for information on custom reaction arms.

Installing the Reaction Arm

Slide the reaction arm onto the spline or serpentine fitting and secure the snap ring to hold the reaction arm in place. Couple the socket and square drive together with a dowel pin and secure with a locking ring.

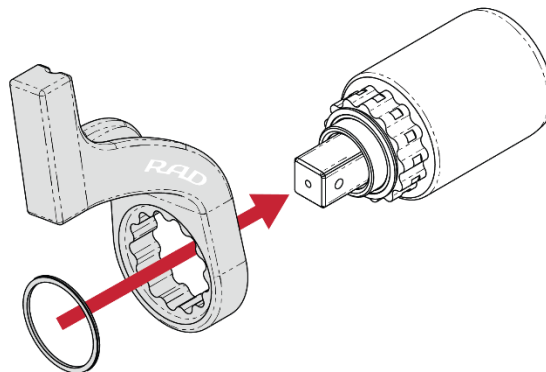

Reaction Points

Make sure that the reaction arm is in contact with a solid reaction point before operating the tool.

When the tool is in operation, the reaction arm rotates in the opposite direction to the output square drive and must be allowed to rest squarely against a solid object or surface adjacent to the bolt to be tightened.

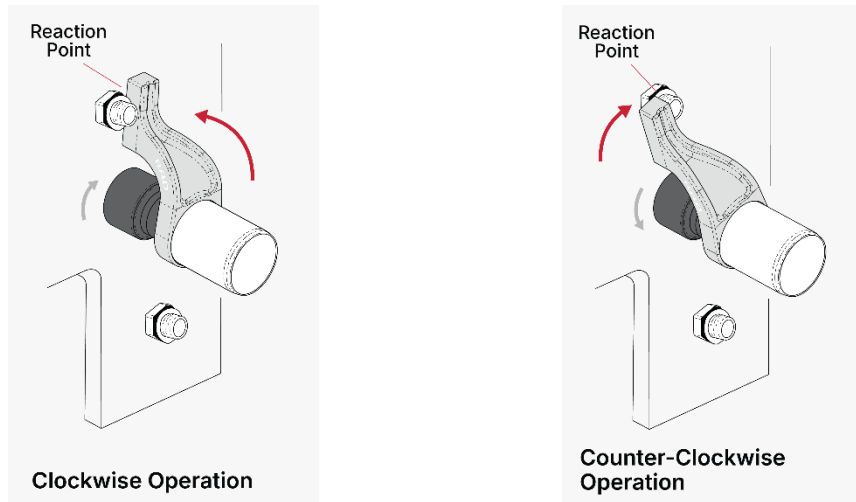

Personal Safety



CAUTION!

Keep hands clear of the reaction arm and joint when the tool is in operation.



Reaction Arm Height

For proper tool function, ensure that the height of the socket is even with the height of the reaction arm.

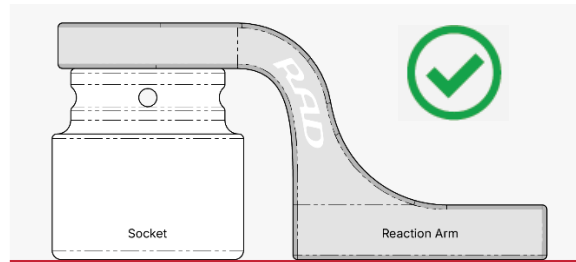

Correct: The socket and reaction arm are aligned

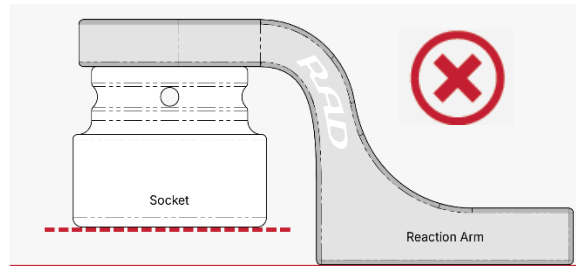
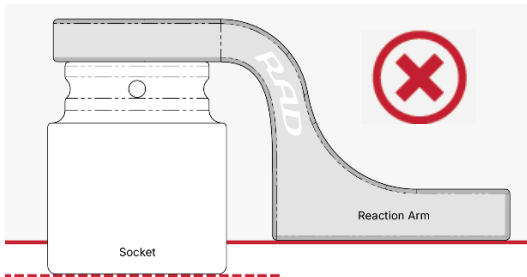

Incorrect: The leg of the reaction arm is too short in the left image and too long in the right image

Reaction Arm Foot

Make sure the foot of the reaction arm is positioned directly against the reaction point to ensure correct function

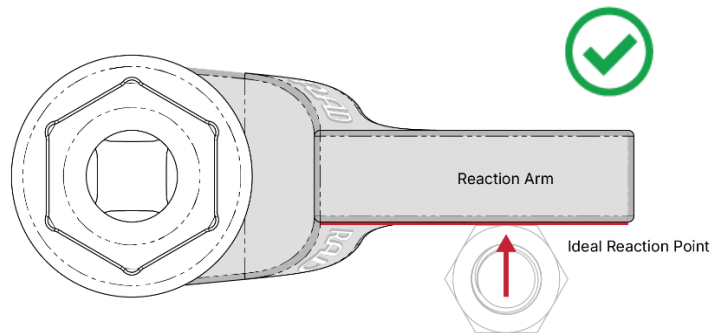

Reaction Point

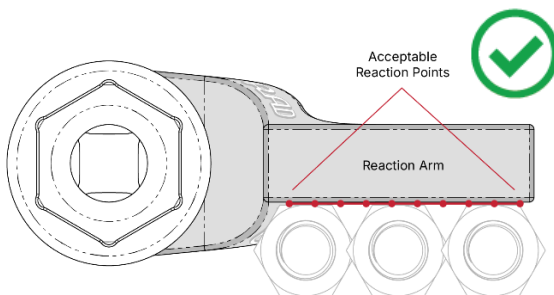

Good reaction point:
Reacting perpendicular to the reaction arm

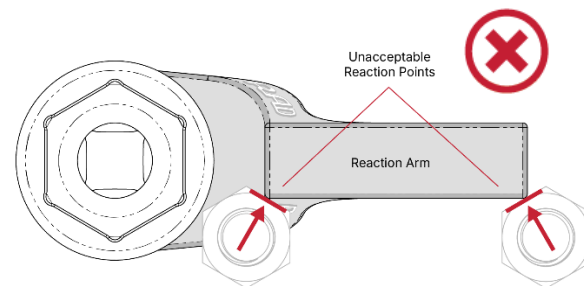

Bad reaction point:
Reacting at the angle towards the heel or the toe of the reaction arm

4.2 Torque Operation

To operate the tool in a torque cycle:

1. Ensure the tool is in Torque Select Mode (Figure 4.2-1).
2. Ensure the display is showing the correct units (see Section 3.3.9 Settings – Unit Selection).
3. Change the torque value as desired.

Note: Refer to the following sections to set the torque: Section 3.2.1 Change the Target Torque, Section 3.2.3 Select Preset – Customerpreset, or Section 3.2.4 Select Preset – HV-Preset).

4. The tool is ready to torque at the displayed setting.
5. Ensure the forward/reverse switch is in the forward position. The top left side will have “Clockwise” displayed as seen in Figure 4.2-1.
6. Press and release on/off trigger to ensure tool is awake.
7. Press and hold the on/off trigger.

Note: To stop the torque cycle at any time, release the on/off trigger.

8. When the B-RAD S reaches the selected torque, the tool will stop turning. Release the on/off trigger.

Note: Cycle result will be shown on screen in green on a passed cycle and red on a failed cycle.



Figure 4.2-1: Torque Select Mode

4.3 Torque and Angle Operation

To operate the tool in a torque and angle cycle:

1. Ensure the tool is in Torque and Angle Select Mode (Figure 4.3-1).
2. Ensure the display is showing the correct units (see Section 3.3.9 Settings – Unit Selection).
3. Change the torque value as desired.

Note: Refer to the following sections to set the torque: Section 3.2.1 Change the Target Torque, Section 3.2.2 Change the Target Angle, Section 3.2.3 Select Preset – Customerpreset, or Section 3.2.4 Select Preset – HV-Preset).

4. The tool is ready to torque at the displayed setting.
5. Ensure the forward/reverse switch is in the forward position. The top left side will have “Clockwise” displayed as seen in Figure 4.3-1.
6. Press and release on/off trigger to ensure tool is awake.
7. Press and hold the on/off trigger.

Note: To stop the torque cycle at any time, release the on/off trigger.

8. When the B-RAD S reaches the selected torque, the tool will stop turning. Release the on/off trigger.



Figure 4.3-1: Torque and Angle Select Mode

4.4 Check-Program Mode Operation



CAUTION!

DO NOT use Check-Program Mode to run down or seat a bolt. The tool will become prone to overheating.

To operate in Check-Program Mode:

1. Ensure that the tool is in Check-Program Mode as in Figure 4.4-1 (see Section 3.2.6 Check-Program Mode).

Note: If pass/fail functionality is desired, ensure Limits are enabled and set (see Section 3.3.3 Settings – Limits).

2. Ensure the display is showing the correct units (see Section 3.3.9 Settings – Unit Selection).
3. Change the torque value as desired.

Note: Refer to the following sections to set the torque: Section 3.2.1 Change the Target Torque, Section 3.2.2 Change the Target Angle, Section 3.2.3 Select Preset – Customerpreset, or Section 3.2.4 Select Preset – HV-Preset).

9. The tool is ready to torque at the displayed setting.
10. Ensure the forward/reverse switch is in the forward position. The top left side will have “Clockwise” displayed as seen in Figure 4.4-1.
11. Press and release on/off trigger to ensure tool is awake.
12. Press and hold the on/off trigger.
Note: To stop the torque cycle at any time, release the on/off trigger.
13. When the B-RAD S reaches the selected torque, the tool will stop turning. Release the on/off trigger.



Figure 4.4-1: Check-Program Mode

5.0 CALIBRATION



CAUTION!

Only qualified personnel with training in the safe operation of torque tooling and the B-RAD S Tool System should operate this tool. Improper use of the calibration function will result in tool damage.

Do not calibrate at target torques that result in exceeding the B-RAD S Tool System's torque range. Severe tool damage will occur.

This function allows the operator to access the calibration values for the B-RAD. These values should only be modified by a qualified calibration technician and using a calibration stand.

5.1 Entering Calibration Mode

The calibration functions are only available when the B-RAD S Tool System is unlocked with the "Advanced" passcode. Contact New World Technologies Inc. Technical Support for more information.

To unlock the Calibration Menu:

1. While in the Main Menu, navigate to the "Extended" option (Figure 5.1-1).
2. Enter the Advanced passcode.
3. Press either the **+** or **-** button until the desired digit appears (Figure 5.1-2).
4. Press the "RAD" button to accept and advance to next digit.
5. Once the passcode is entered, the Main Menu (Figure 5.1-1) will reappear.
6. Re-select "Extended" option.
7. From the Extended Menu select the "Maintenance" option (Figure 5.1-3).
8. From the Maintenance Menu select the "Calibration" option (Figure 5.1-4) for the main Calibration Mode or the "Sensorcal" option (Figure 5.1-5) for the Sensor Calibration Mode.
9. The tool is now in Calibration Mode.

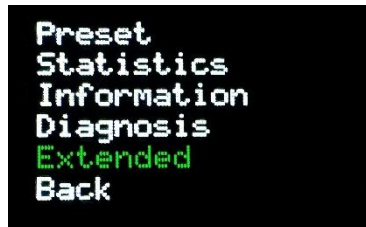

Figure 5.1-1: Main Menu - Extended



Figure 5.1-2: Password Entry



Figure 5.1-3: Extended Menu



Figure 5.1-4: Maintenance Menu - Calibration



Figure 5.1-5: Maintenance Menu - Sensor Calibration

5.2 Table of Calibration Menus

The order and function of the menus in Calibration Mode are outlined in Table 5.2 below.

Menu Title	Description of Function
Minimal Torque (Norm)	Minimum torque limit – Set to 10% of the maximum for the attached gearbox. This is preset at the factory and should only be altered after consulting the manufacturer.
Maximal Torque (Norm)	Maximum torque limit – Set to the maximum for the attached gearbox. This is preset at the factory and should only be altered after consulting the manufacturer.
Minimal Impulse (Norm)	Speed setting at minimum torque for “Normal Mode” – Starts at “1” being slowest and increases. This is preset at the factory and should only be altered after consulting the manufacturer.
Maximal Impulse (Norm)	Speed setting at maximum torque for “Normal Mode” – Starts at “1” being slowest and increases. This is preset at the factory and should only be altered after consulting the manufacturer.
Set xxx, ..., Set xxxx (7 settings) (Norm)	Tool normal calibration points – Calibrates “Normal Mode” output torque at 7 points over the output range.
Minimal Impulse (Prove)	Speed setting at minimum torque for “Prove Mode” – Starts at “1” being slowest and increases. This is preset at the factory and should only be altered after consulting the manufacturer.
Maximal Impulse (Prove)	Speed setting at maximum torque for “Prove Mode” – Starts at “1” being slowest and increases. This is preset at the factory and should only be altered after consulting the manufacturer.
Set xxx, ..., Set xxxx (6 settings) (Prove)	Tool prove calibration points – Calibrates “Prove Mode” output torque at 6 points over the output range.
Set Angle	Set how many pulses the motor produces to turn the square drive by 360°. This number is generally 12 × the gearbox ratio. This is preset at the factory and should only be altered after consulting the manufacturer. To verify the setting, mark the 0 spot on the square drive and the stationary annulus, then pull the trigger and note where the mark returns when the motor power is shut off.
Serial Number	Tool serial number. One letter at start and six trailing numbers are possible. The serial number is displayed on the information screen and appears as the device name on PC for activated documentation.
Save	Save all changes and exit.

Table 5.2-1: Calibration Menu Titles and Functions

5.3 Calibration Procedure



CAUTION!

All changes in calibration have effects on the function of the electric torque wrench. Every fault could result in malfunction or in destruction of the tool.

In Calibration Mode there is no gearbox protection. Always keep an eye on the display of the calibration unit. When the gearbox maximum is exceeded turn-off the tool immediately.

DO NOT operate the B-RAD S Tool System beyond 50 units above the rated maximum torque. Over-torquing the tool will cause severe tool damage.

IMPORTANT!

All bolting results must be reached in the range of $\pm 3.5\%$ around the target value.

To calibrate the B-RAD S:

1. Install a fresh battery into the B-RAD S.
2. Turn on the tool. Wait for the last torque value to be displayed.
3. Once in main Calibration Mode (see section 5.1). Use the **+** and **-** buttons to navigate through the Calibration Menu (see Table 5.2-1). Select the calibration step by pressing the **"RAD"** button. Select the value with the **+** and **-** buttons and save by pressing the **"RAD"** button again.
4. Go to the first "Set xxx" for Normal Mode.
5. Follow these steps to calibrate the "Set xxx":
 - i. The "xxx" value for "Set xxx" is the target torque.
 - ii. Press and hold the trigger of the tool.
 - iii. The tool shuts-off at the preset current value automatically.
 - iv. After shut-off, compare the torque displayed at the test bench with the target torque displayed on the tool.
 - v. Adjust the shut-off value if necessary. For this press the **"RAD"** button, which will change the color of the number, then set the shut-off value by using the **+** and **-** buttons. Save by pressing the **"RAD"** button again.
 - vi. Keep executing this step until the displayed torque on the test bench complies with the required shut-off value.
6. Use the **+** and **-** buttons to navigate to the next "Set xxx" calibration point for Normal Mode and repeat Step 5 for each of the seven.
7. Repeat Step 5 for each of the six "Set xxx" calibration points under the Prove Mode as well.

5.4 Sensor Calibration Procedure



CAUTION!

All changes in calibration have effects on the function of the electric torque wrench. Every fault could result in malfunction or in destruction of the tool.

In Calibration Mode there is no gearbox protection. Always keep an eye on the display of the calibration unit. When the gearbox maximum is exceeded turn-off the tool immediately.

DO NOT perform a sensor calibration on the B-RAD S Tool System before the main calibration is complete as damage may occur to the system.

To calibrate the sensor of the B-RAD S:

1. Install a fresh battery into the B-RAD S.
2. Turn on the tool. Wait for the last torque value to be displayed.
3. Once in the Sensor Calibration Mode (see section 5.1) the tool will be on the "Zero Point Setting" (Figure 5.4-1).
4. With the tool resting on a flat surface and no pressure placed on the end of the gearbox, pull the trigger briefly. The "0" will go from white to green to indicate it is set.

Note: Any pressure on the annulus may offset the calibration.

5. Press **■** button to go to the "Max Torque Setting" (Figure 5.4-2).
6. Perform a torque cycle on a test bench.
7. Press the "RAD" button to highlight the numbers in yellow and adjust them to match the torque displayed at the test bench.
8. Press "RAD" button to accept changes.
9. Use the navigation buttons to go to the Save Screen to save changes or to the Abort Screen to ignore changes.
10. When on desired selection press the "RAD" button to exit to Maintenance Menu.



Figure 5.4-1: Sensorcal – Zero Point Setting



Figure 5.4-2: Sensorcal – Max Torque Setting

6.0 B-RAD DATA LOGGER

The B-RAD Data Logger is a PC software package designed to connect the B-RAD S to a computer for data logging. This section covers the how to download the B-RAD Datalogger Software, connect the B-RAD S to a computer and download data logs from the tool. The data logger program will organize all records by the tool's serial number. The "Tool" drop-down will display all previously uploaded tool serial numbers and the "File" drop-down will display it's corresponding records.



6.0-1: Main Screen of B-RAD Datalogger with No Logs Open

6.1 Downloading the B-RAD Data Logger

To Download the B-RAD Data Logger:

1. Open the website www.radtorque.com/resources/
2. Scroll down to the B-RAD S section of the page or use the filters to select B-RAD S.
Note: The B-RAD S is part of the "Audit Equipment" series.
3. Select "**B-RAD S Data Logger**". It will open Dropbox.
4. Download the files, select "setup.exe" and follow the installation instructions.

6.2 Pairing the Tool

6.2.1 Opening the Bluetooth® Menu

1. Open the Bluetooth® Menu on a Windows computer which has B-RAD Datalogger Software installed.
2. Set the Bluetooth® discoverability to on.

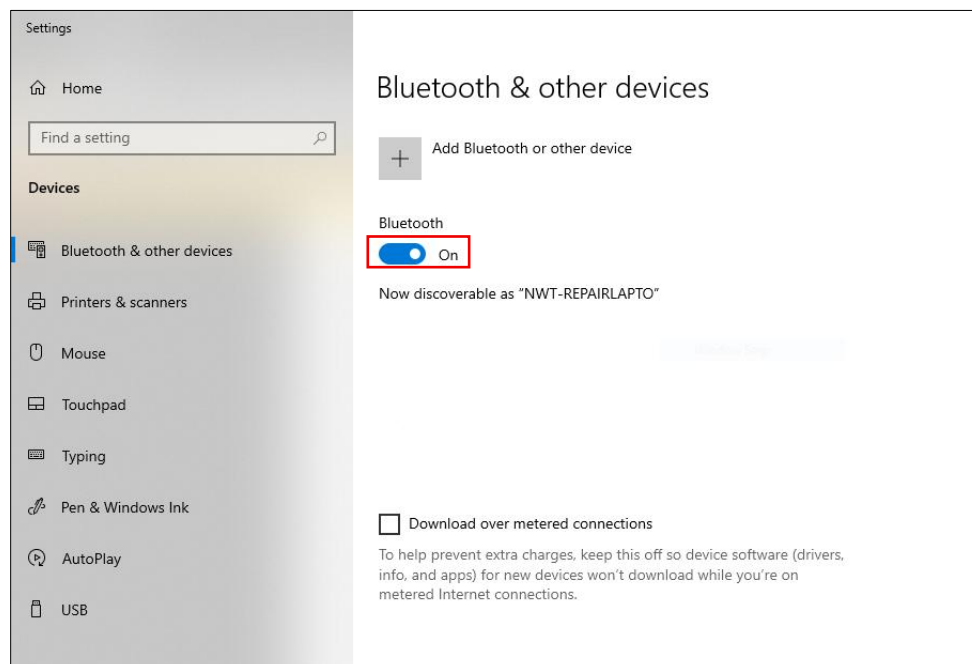

Figure 6.2.1-1: Windows 10 Bluetooth® Screen with Bluetooth® Set to On

6.2.2 Add a Device to PC

1. Select the "Bluetooth®" option (Figure 6.2.2-1).

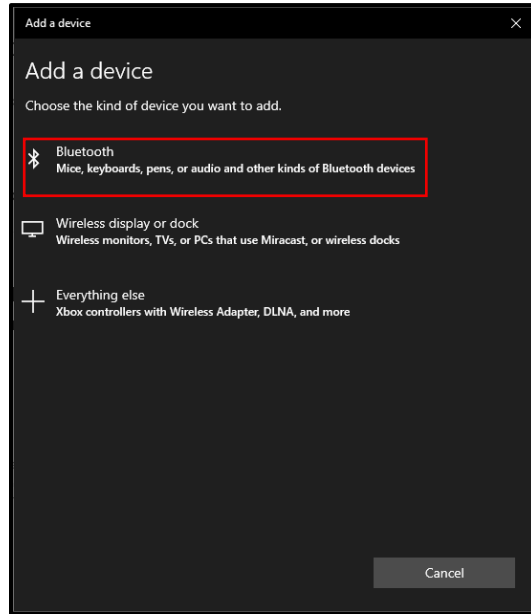

Figure 6.2.2-1: Add a Device

2. The Bluetooth® controller will now find the Tool labeled as its gearbox number (Figure 6.2.2-2).

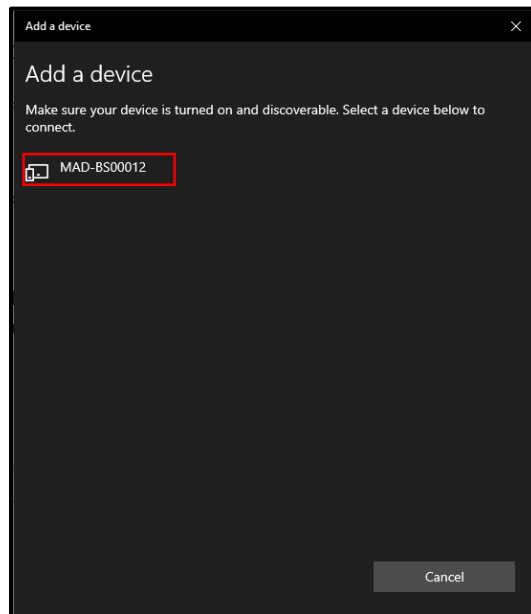

Figure 6.2.2-2: Choose the Device

3. Select the tool and wait for the computer to pair (Figure 6.2.2-3). Press **“Done”**. The tool is now paired with the PC.

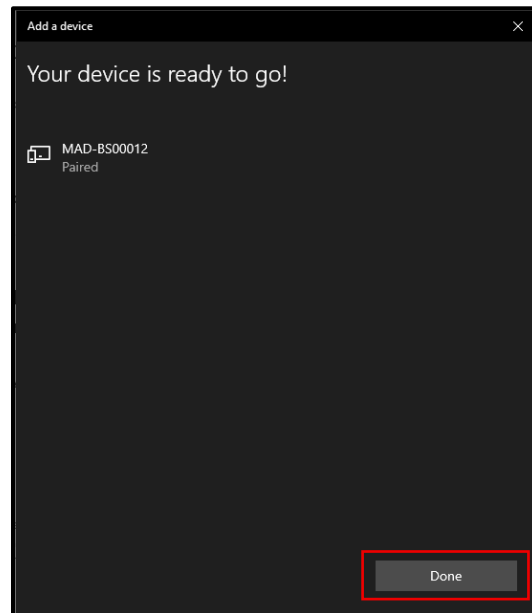

Figure 6.2.2-3: Pairing Complete Confirmation

6.2.3 Finding COM Ports Over Bluetooth®

B-RAD Datalogger pairs with the COM ports on the computer through a Bluetooth® controller.

To find which ports the tool is connecting to, open the Device Manager on the computer and expand the “Ports” category to reveal which ports are connecting through Bluetooth®. These Standard Serial over Bluetooth® link options will appear when the tool is paired with the computer’s Bluetooth® controller.

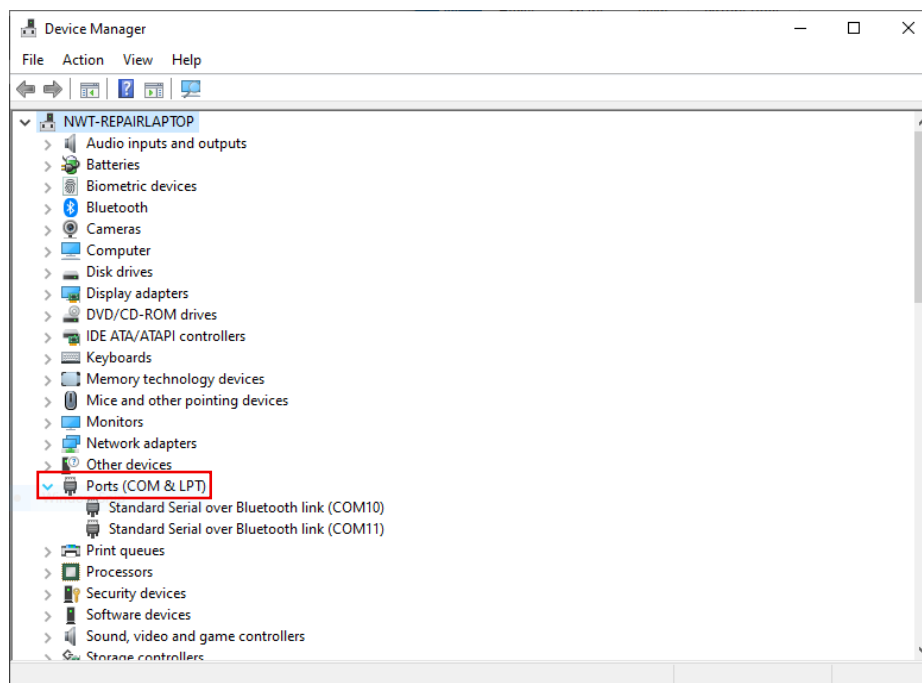

Figure 6.2.3-1: Device Manager Showing Bluetooth® Connections

6.3 Downloading Data Logs

Note: This process must be done in sequence and if done incorrectly will require a restart of the B-RAD Datalogger

To download data logs:

1. With the tool paired to the Bluetooth® controller, open B-RAD Datalogger.
2. Use the **"Select COM"** drop-down to select the port that the tool is connected to.
Note: The tool will generate 2 different COM port readings. If the first attempt to connect is unsuccessful, restart the program and try the alternative COM number.

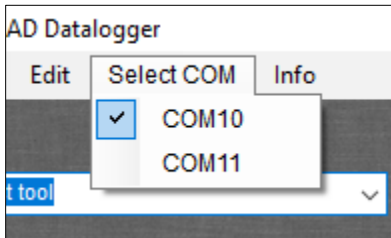

Figure 6.3-1: Select COM Menu

3. Press the **"Load file"** button. This will open the "Activate" prompt. Do not press "OK" until completing the next step (Figure 6.3-2).

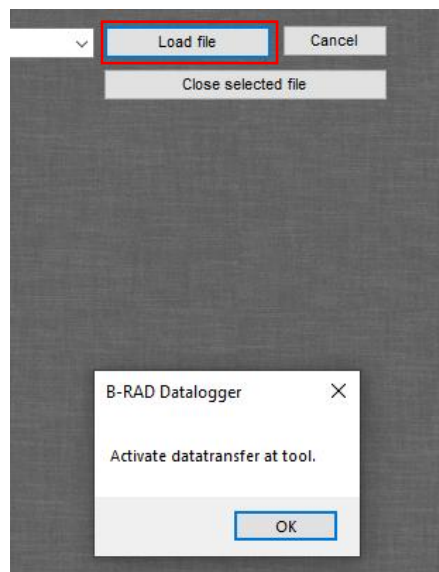

Figure 6.3-2: Load File

4. Set the B-RAD S into Datatransfer Mode. See Section 3.3.16 Data Logging – Setting – Data Transfer.
5. Press **"OK"** on the "Activate datatransfer at tool" pop up (Figure 6.3-3).

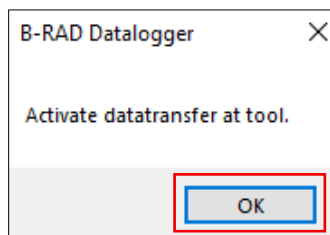

Figure 6.3-3: Activate Datatransfer Prompt

Now that the tool is in Datalogger Mode and paired to the PC, it will send its files through Bluetooth® to the B-RAD Datalogger. At the bottom of the screen in the B-RAD Datalogger the text "Connecting..." (Figure 6.3-4) should appear briefly before the transfer starts (Figure 6.3-5).

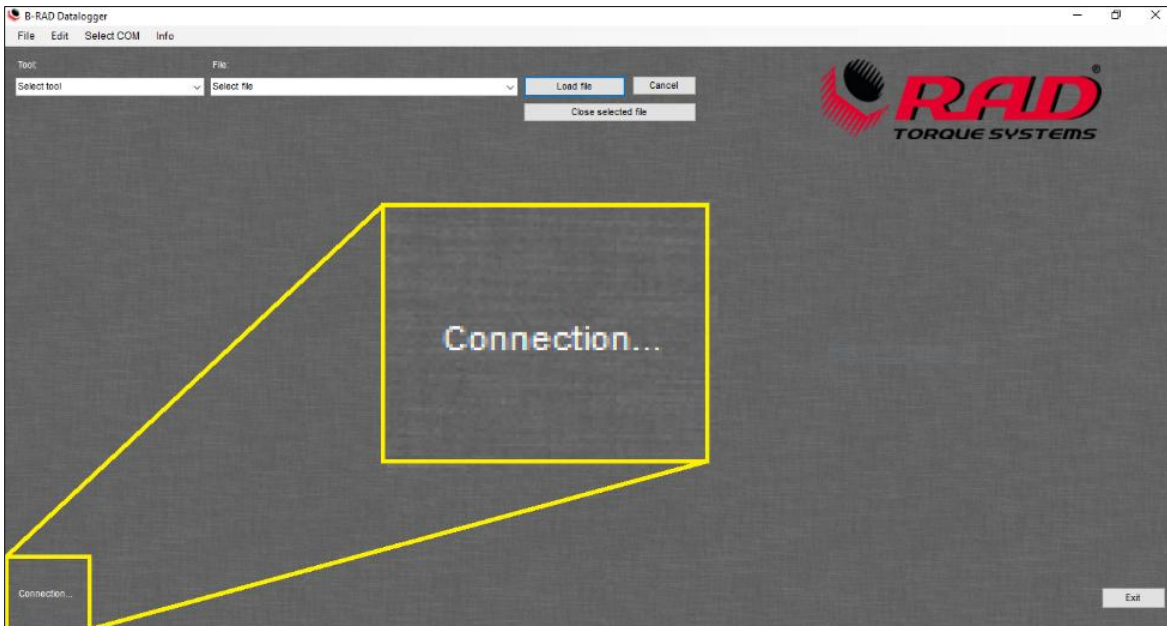

Figure 6.3-4: Connecting to the Tool



Figure 6.3-5: File Transfer In Progress

6.4 Viewing Log Files

When the upload is complete, the program will display the logs by serial number and log file name.

If there is more than one log file on the drill, the other logs can be viewed by selecting them from the drop down "**File**" and pressing "**Load file**".

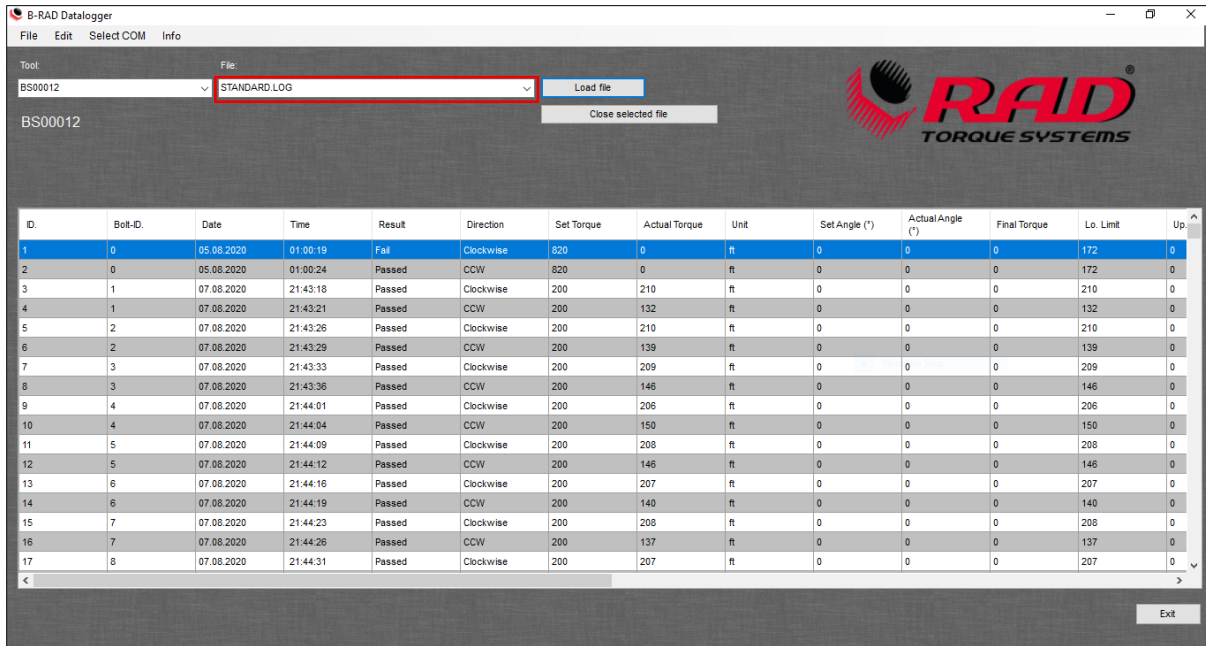

Figure 6.4-1: Viewing Data Logs

6.5 Closing Data Logs

To upload logs to the computer without deleting them from the tool, simply disconnect the tool without closing the log file.

To close a data log file:

1. Make sure the desired data log is selected in the "File" selection.
2. Press "**Close selected file**".
3. A dialog popup will say "File will only be deleted from tool". Select "**OK**" to close the log and delete the logs or select "**Cancel**" to go back to viewing the logs.

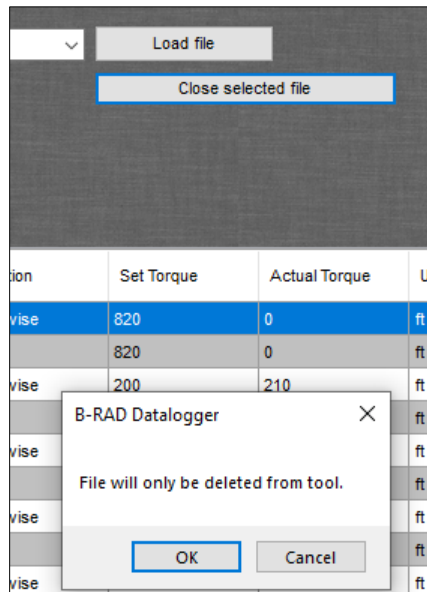

Figure 6.5-1: Closing the Log File

Once the log file is closed, the time and date will be appended to the end of the log name (Figure 6.5-2). This is an easy way to determine if a log file is open or closed.



Figure 6.5-2: Closed Log File

6.6 Exporting Data Files

To export a log file:

1. Select the data logger's "File" drop down menu.
2. Select "Export"
3. Select the desired file type to export as from the list (Figure 6.6-1).

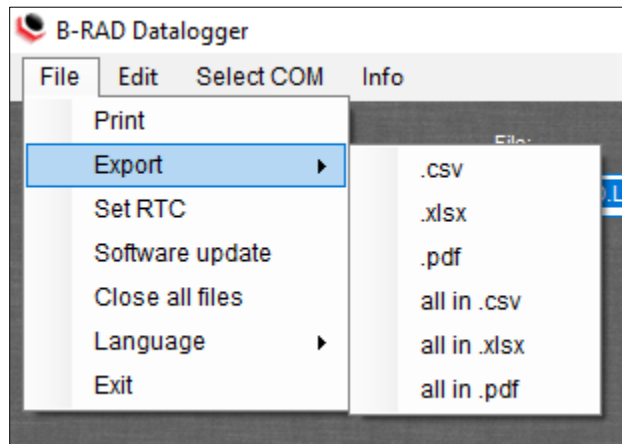

Figure 6.6-1: Export Menu

7.0 TROUBLESHOOTING



IMPORTANT!

Disassembling or attempting repair will void warranty.

If breakdown, malfunction, or error occurs, contact New World Technologies Inc. Technical Support (refer to Section 8.0 – Contact Us).

The display module may exhibit abnormal behaviour depending on operating conditions, frequency of use, or excessive wear on the display module.

The display module is designed to withstand normal use over the lifetime of the B-RAD S Tool System; however, as a sensitive electronic device it is susceptible to damage caused by shock, moisture, or excessive force.

7.1 Errors and Solutions

In case of an error or problem, the B-RAD S display will display an error message and disable tool operation. Table 7.1-1 lists error messages, problems that may occur, and possible solutions to the problem.

Note: If the problem or error persists after following solution instructions, contact New World Technologies Inc. Technical Support (refer to Section 8.0 – Contact Us).

Error	Symptoms/Reasons	Possible Solution(s)
Error overheating	The motor, battery, or control electronics are too hot.	Let the device cool down.
Insert SD card	SD card was not recognized.	Contact your RAD distributor for assistance.
Zero point	There is load on the gearbox when the B-RAD S is turned on.	Unload the tool.
Error sensor	The sensor electronics are not sending any measured values.	Contact your RAD distributor for assistance. Note: To complete work, the sensor function can be deactivated in the extended menu (cycle power after).
Only dashes appear on the display instead of letters	SD card was not recognized.	Contact your RAD distributor for assistance.
Date and time incorrect	<ol style="list-style-type: none"> 1. Different time zone 2. Internal battery empty 	<ol style="list-style-type: none"> 1. Go to Extended>Date/Time to set. 2. Contact your RAD distributor for assistance.
Minimum or maximum torque cannot be set	<ol style="list-style-type: none"> 1. Calibration incorrect 2. Internal memory defective 	<ol style="list-style-type: none"> 1. Check the calibration and if needed re-calibrate. 2. Contact your RAD distributor for assistance.
Device no longer responds to buttons	<ol style="list-style-type: none"> 1. Internal software error 2. Membrane keyboard defective 	<ol style="list-style-type: none"> 1. The device must be restarted. 2. Contact your RAD distributor for assistance.
Trigger is pressed and device does not start	<ol style="list-style-type: none"> 1. Torque setting set to 0. 2. Bolt counter activated and set to 0. 3. Bolt counter activated and all bolt operations completed. 4. Trigger is defective. 	<ol style="list-style-type: none"> 1. Set torque to something other than 0. 2. Adjust the bolt counter to something other than 0. 3. Start a new operation. 4. Contact your RAD distributor for assistance.

Device does not loosen the bolts in counterclockwise rotation	<ol style="list-style-type: none"> 1. Required torque is higher than the maximum torque of the B-RAD S. 2. Forward/reverse switch defective 	<ol style="list-style-type: none"> 1. Choose a larger tool to complete cycle. 2. Contact your RAD distributor for assistance.
Device shows an error message after cycle	<ol style="list-style-type: none"> 1. Limits are active and set incorrectly. 2. Limits are active and tolerance is set incorrectly. 3. Tried to re-tighten a tightened bolt. 4. The B-RAD S reached its maximum torque when tightening during angle rotation. 5. The trigger was released before the device completed its cycle. 	<ol style="list-style-type: none"> 1. Adjust the limits. 2. Adjust the tolerance. 3. If trying to check the tightness of a tightened bolt then switch over to Check-Program Mode (see Section 3.2.6 – Check-Program Mode). 4. To protect the B-RAD S Tool System the tool switches off automatically and returns an error message. 5. The trigger must be fully depressed until the tool completely stops on its own.

Table 7.1-1: Common Errors and Solutions

8.0 CONTACT Us

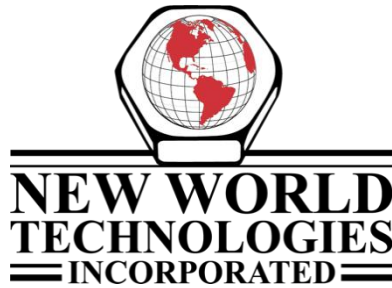

TF: 1-800-983-0044 **F:** 604-852-0269

W: www.radtorque.com **E:** info@radtorque.com

Technical Support

P: 1-800-983-0044 (EXT. 227)

E: service@radtorque.com

New World Technologies Inc.

100-30722 Marshall Road
Abbotsford, BC V2T 0H9
Canada



The Bluetooth® word mark and logos are registered trademarks of Bluetooth SIG, Inc. and any use of such marks by New World Technologies Inc. is under license. Other trademarks and trade names are those of their respective owners.

B-RAD S LIMITED WARRANTY

NEW TOOL WARRANTY

Any new tool branded with the RAD name and purchased from New World Technologies Inc., or through one of its authorized distributors or agents, is warranted to the original purchaser against defects in materials and workmanship for a period of one (1) year from the date of original calibration. Electric drive components such as electric motors, switches, and batteries etc., are covered for a period of six (6) months from the date of original calibration. Under the terms of this warranty, New World Technologies Inc., at its option and F.O.B. either its factory or an authorized service center, will replace or repair for the original purchaser, free of charge, any part or parts, found upon examination by New World Technologies Inc., to be defective in material or workmanship or both. If any product or part is replaced or repaired under the terms of this warranty, that product or part will carry the remainder of the warranty from the date of original calibration.

REPAIRED TOOL WARRANTY

Once a tool is beyond its new tool warranty, New World Technologies Inc., for a period of three (3) months from the date of repair, will replace or repair for the original purchaser, free of charge, any part or parts, found upon examination by New World Technologies Inc., to be defective in material or workmanship or both. If any product or part is replaced or repaired under the terms and conditions of this warranty, that product or part will carry the remainder of the warranty from the date of original repair.

To qualify for the above mentioned warranties, written notice to New World Technologies Inc. must be given immediately upon discovery of such defect, at which time New World Technologies Inc. will issue an authorization to return the tool. The defective item must promptly be returned to New World Technologies Inc. all freight charges prepaid. When returning a tool, the reaction arms being used with the tool must also be returned.

NEW WORLD TECHNOLOGIES INC. | T: 1.800.983.0044 | E: INFO@RADTORQUE.COM

EXCLUSIONS FROM WARRANTY

Tools or accessories found by New World Technologies Inc.'s sole judgement to have been altered, damaged, misused, abused, badly worn due to excessive utilization, lost, or improperly maintained will NOT be covered under the terms of this warranty.

Tools returned without the reaction arms will not be covered under the terms of this warranty.

Consumable parts and accessories (such as extensions, reaction blanks/arms) are not covered under this warranty.

Tools that have been relabeled without prior written consent of New World Technologies Inc. will not be covered under this warranty.

Equipment and accessories not manufactured by New World Technologies Inc. (measuring equipment, etc.) are warranted only to the extent of the original manufacturer's warranty.

**There is no other express warranty. Implied warranties, including those of merchantability and fitness for a particular purpose are limited to one year from date of calibration and to the extent permitted by law. Liability for consequential damages under any and all warranties are excluded to the extent exclusion is permitted by law.*

LIGHTER FASTER STRONGER SAFER



ABOUT NEW WORLD TECHNOLOGIES INC.

New World Technologies is a leading Canadian manufacturer of pneumatic, battery powered, and electronic pistol grip torque wrenches. Our advanced products have proven to be successful all over the world in such industries as oil and gas, petrochemical, mining, aerospace, and manufacturing. We continue to invest in and employ the latest technology to achieve the highest level of Innovation, quality, and performance - which has resulted in multiple patents for our products.



NEW WORLD TECHNOLOGIES INC

#100 - 30722 MARSHALL RD | ABBOTSFORD, BC V2T 0H9 | CANADA
604.852.0405 | INFO@RADTORQUE.COM | RADTORQUE.COM