



ADVANCED
BOLTING
TECHNOLOGY



PNEUMATIC



ELECTRONIC



BATTERY



ELECTRIC



SMART SOCKET

WWW.RADTORQUE.COM

B-RAD BL SELECT
USER MANUAL

RAD TORQUE SYSTEMS

PNEUMATIC SERIES



- **PATENTED PLANETARY GEAR REDUCTION**
Delivers one of the highest power-to-weight ratios of any pneumatic controlled bolting system
- **SMOOTH CONTINUOUS FLOW OF CONTROLLED TORQUE**
Eliminates destructive hammering
- **LIGHTWEIGHT ERGONOMIC PISTOL GRIP DESIGN**
Reduces operator strain and injury; resulting in increased productivity
- **UNMATCHED RELIABILITY AND QUALITY**
Delivered by one of the most advanced engineered gear boxes on the market

ELECTRONIC SERIES E-RAD



- **PUSH-BUTTON SELECT TORQUE**
Fast and convenient error-free digital single increment torque settings
- **DIGITAL TORQUE CONSOLE DISPLAY**
Maximum accuracy by seeing the set torque value and the actual delivered torque value
- **LIGHTWEIGHT AND ERGONOMIC PISTOL GRIP DESIGN**
Advanced low-profile handle to reduce operator fatigue and increase productivity
- **EXTREMELY LOW NOISE LEVEL ONLY 75DB**
World's quietest extreme torque gun, ideal for sensitive environments and standards
- **LED GREEN (PASS) OR RED (FAIL) INDICATOR LIGHTS**
Unmistakable visual signal indicates status of torque procedure for maximum accuracy and speed

BATTERY SERIES B-RAD



- **QUICK ADJUST TORQUE SETTINGS**
Fast and accurate "dial a torque" for maximum versatility and efficiency
- **SOFT-START VARY SPEED TRIGGER**
Allows operator to safely and quickly set reaction arm before full torque is applied
- **EQUAL POWER IN FORWARD AND REVERSE**
Convenience and cost effective use of same tool for break away and final torque
- **IMAGINE THE FREEDOM - NO AIR LINES, NO POWER CORDS!**
The lightweight design of the B-SERIES makes it ideal for any application, especially where compressed air and electricity are not readily available.
- **ADVANCED GEARBOX DESIGN**
PATENTED planetary gear reduction drive system delivering one of the highest power-to-weight ratios of any controlled bolting system

ELECTRIC SERIES V-RAD



- **QUICK ADJUST TORQUE SETTINGS**
Fast and accurate "dial a torque" for maximum versatility and efficiency
- **SOFT-START VARY SPEED TRIGGER**
Allows operator to safely and quickly set reaction arm before full torque is applied
- **EQUAL POWER IN FORWARD AND REVERSE**
Convenience and cost effective use of same tool for break away and final torque
- **ADVANCED ULTRA-DURABLE ELECTRIC MOTOR DESIGN**
Extreme duty designed to reduce maintenance cost and increase reliability
- **ADVANCED GEARBOX DESIGN**
Patented planetary gear reduction drive system delivering one of the highest power-to-weight ratios of any controlled bolting system

SMART SOCKET™ SERIES



- **MEASURE AND DISPLAY PEAK TORQUE**
Transducer technology combined with a custom socket measures the actual torque applied to the bolt during a torque cycle.
- **PASS OR FAIL INDICATION**
Unmistakable digital signal indicates peak torque achieved for maximum accuracy
- **BLUETOOTH® TECHNOLOGY**
View and download logs onto your smartphone or tablet
- **IDEAL ON SITE CALIBRATION TOOLS**
Comparable in size to a standard socket, it's the perfect tool for inspecting bolted joints and can function as a master calibrator for your torque tools

NOTICE:
 This manual applies to the following hardware and firmware release:
B-RAD Select Brushless
V07-14-17-41
 Use with any other firmware version may produce unexpected results.

TABLE OF CONTENTS

Manual Revision History	3
Important Safety Notice	4
General Power Tool Safety Warnings	4
Battery Pack Safety Warnings	6
1. General Information	7
1.1 System Components	7
1.2 Specifications	8
1.2.1 Tool Model Specifications	8
1.2.2 Battery Specifications	8
1.2.3 Environmental Specifications	9
1.2.4 Cycle of Operation	9
2. Tool System	10
2.1 Tool Handle	10
2.1.1 Trigger Lock.....	10
2.2 LED Display Module	11
2.3 RAD Li-Ion Battery Pack	11
2.3.1 Insert/Remove the RAD Li-Ion Battery Pack.....	12
2.3.2 Check RAD Battery Charge	12
2.4 RAD Battery Charger	12
2.4.1 Charging the RAD Li-Ion Battery Pack.....	13
2.4.2 Charging Errors	13
3. Interface And Settings	14
3.1 Changing Torque	14
3.2 Information Menu	15
3.2.1 Change the Torque Units.....	15
3.2.2 View the Battery Voltage.....	15
3.2.3 View Tool Temperature.....	16
3.2.4 Change the LED Brightness	16
3.2.5 Enter a Lock or Unlock Code	16
3.2.6 View Program Version.....	17
3.3 Tool Menu	17
3.4 Unlock Levels	18
4. General Operating Instructions	19
4.1 Reaction Arm	19
Installing the Reaction Arm.....	19
Reaction Points.....	20
Personal Safety.....	20
Reaction Arm Height.....	21
Reaction Arm Foot.....	21
Reaction Point.....	21
4.2 Torque Operation	22
5. Calibration	23
5.1 Calibration Menu Navigation	23
5.2 Table of Calibration Menus	24
5.3 Table of Tool Models	24



5.4 Two-Hand Safety Modes	25
5.5 Calibration Procedure.....	26
6. Troubleshooting	27
7. Contact Us.....	28

MANUAL REVISION HISTORY

V2018.05.02: Firmware Release V06-10-12

- Updated controller hardware images
- Updated interface operation: Main and Calibration

V2018.06.22: Firmware Release V06-10-13**V2019.06.14:** Firmware Release V06-12-03

- Updates to sections: 3.1 / 3.2 / 3.4 / 4.2 / 5.1 / 5.2

V2020.01.14: Firmware Release V06-12-04-41

- Updates to sections: 5.3

V2022.06.20:

- Updated 7.0 Contact Us: New Address

V2023.03.20:

- Updated 7.0 Contact Us: New Photo

V2023.05.01: Firmware Release V06-14-04-41

- Updated 5.3 Table of Tool Models: New models

V2023.05.05:

- Added Section 5.4 2-Hand Safety Modes

V2023.10.27:

- Updated Section 5.4 with more accurate information
- Updated General Power Tool Safety Warnings Section
- Updated Section 1.2.1 Tool Model Specifications
- Updated Section 1.2.3 Environmental Specifications
- Updated Section 1.2.4 Cycle of Operation
- Updated Section 4 General Operating Instructions

V2024.12.09:

- Updated Section 5.3 with updated range for G05 / G06 / G08 / G14
- Updated Section 3.2.3 to state that Temperature is in Celsius and noted the message displayed when the temperature sensor is disconnected.
- Updated Section 1.2.1 with updated range for 700-M and 6800-M changed to 7000-M
- Updated: 7.0 Contact Us – Bluetooth® trademark statement

V2025.03.20:

- Reformatting of manual

V2025.07.30:

- Font change
- Updated General Power Tool Safety Warnings
- Updated Section 2.4: Image

V2025.12.11:

- Updated Section 4: Images

IMPORTANT SAFETY NOTICE



WARNING!

READ ALL SAFETY WARNINGS, INSTRUCTIONS, ILLUSTRATIONS, AND SPECIFICATIONS PROVIDED WITH THIS POWER TOOL. FAILURE TO FOLLOW ALL INSTRUCTIONS LISTED BELOW MAY RESULT IN ELECTRIC SHOCK, FIRE AND/OR SERIOUS INJURY.

SAVE ALL WARNINGS AND INSTRUCTIONS FOR FUTURE REFERENCE.

GENERAL POWER TOOL SAFETY WARNINGS

The term "power tool" in the warnings refers to your battery-operated (cordless) power tool.

The B-RAD Select Tool System should be inspected before every use.

1. Work Area Safety

- a. **Keep work area clean and well lit.** Cluttered and dark areas invite accidents.
- b. **Do not operate power tools in explosive atmospheres, such as environments with the presence of flammable liquids, gases, or dust.** Power tools create sparks which may ignite the dust or fumes.
- c. **Keep children and bystanders away while operating the power tool.** Distractions can cause you to lose control.

2. Electrical Safety

- a. **Power tool plugs must match the outlet. Never modify the plug in any way. Do not use any adapter plugs with earthed (grounded) power tools.** Unmodified plugs and matching outlets will reduce the risk of electric shock.
- b. **Avoid body contact with earthed or grounded surfaces such as pipes, radiators, ranges, or refrigerators.** There is an increased risk of electric shock if your body is earthed or grounded.
- c. **Do not expose power tools to rain or wet conditions.** Water entering a power tool will increase the risk of electric shock.
- d. **Do not abuse the cord. Never use the cord to carry, pull, or unplug the power tool. Keep cord away from heat, oil, sharp edges, and moving parts.** Damaged or entangled cords increase the risk of electric shock.
- e. **When operating a power tool outdoors, use an extension cord suitable for outdoor use.** Use of a cord suitable for outdoor use reduces the risk of electric shock.
- f. **If operating a power tool in a damp location is unavoidable, use a Ground Fault Circuit Interrupter (GFCI) protected supply.** Use of a GFCI reduces the risk of electric shock.

NOTE: A "Ground Fault Circuit Interrupter (GFCI)" is also known as a "RESIDUAL CURRENT DEVICE (RCD)" or "earth leakage circuit breaker (ELCB)"

3. Personal Safety

- a. **Stay alert, watch what you are doing, and use common sense when operating a power tool. Do not use a power tool while you are tired or under the influence of drugs, alcohol, or medication.** A moment of inattention while operating power tools may result in serious personal injury.
- b. **Use personal protective equipment and always wear eye protection.** Protective equipment such as a dust mask, non-skid safety shoes, hard hat, and hearing protection used in appropriate conditions will reduce personal injuries.
- c. **Prevent unintentional starting by ensuring the switch is in the off position before connecting to a power source and/or BATTERY pack, picking up, or carrying the tool.** Carrying power tools with your finger on the switch or energizing power tools that have the switch on invites accidents.
- d. **Remove any adjusting key or wrench before turning the power tool on.** A wrench or a key left attached to a rotating part of the power tool may result in personal injury.

- e. **Do not overreach. Keep proper footing and balance at all times.** This enables better control of the power tool in unexpected situations.
- f. **Dress properly. Do not wear loose clothing or jewellery. Keep your hair, clothing, and gloves away from moving parts.** Loose clothes, jewellery or long hair can be caught in moving parts.
- g. **If devices are provided for the connection of dust extraction and collection facilities, ensure these are connected and properly used.** Use of dust collection can reduce dust-related hazards.
- h. **Do not let familiarity gained from frequent use of tools allow you to become complacent and ignore tool safety principles.** A careless action can cause severe injury within a fraction of a second.
- i. **Keep all body parts clear of moving parts and the reaction contact point.** Careless placement can cause severe injury within a fraction of a second.

4. Power Tool Use and Care

- a. **Do not force the power tool. Use the correct power tool for your application.** The correct power tool will do the job better and safer at the rate for which it was designed.
- b. **Do not use the power tool if the switch does not turn it on and off.** A power tool that cannot be controlled with the switch is dangerous and must be repaired.
- c. **Disconnect the power source and/or the BATTERY pack from the power tool before making any adjustments, changing accessories or storing power tools.** Such preventive measures reduce the risk of starting the power tool accidentally.
- d. **Store idle power tools out of the reach of children and do not allow persons unfamiliar with the power tool or these instructions to operate the power tool.** Power tools are dangerous in the hands of untrained users.
- e. **Maintain power tools and accessories. Check for misalignment or binding of moving parts, breakage of parts, and any other condition that may affect the power tool's operation. If damaged, have the power tool repaired before use.** Many accidents are caused by poorly maintained power tools.
- f. **Keep cutting tools sharp and clean.** Properly maintained cutting tools with sharp cutting edges are less likely to bind and are easier to control.
- g. **Use the power tool, accessories, and tool bits etc. in accordance with these instructions, taking into account the working conditions and the work to be performed.** Use of the power tool for operations different from those intended could result in a hazardous situation.
- h. **Keep handles and grasping surfaces dry, clean, and free from oil and grease.** Slippery handles and grasping surfaces do not allow for safe handling and control of the tool in unexpected situations.

5. BATTERY tool use and care

- a. **Recharge only with the charger specified by the manufacturer.** A charger that is suitable for one type of BATTERY pack may create a risk of fire when used with another BATTERY pack.
- b. **Use power tools only with specifically designated BATTERY packs.** Use of any other BATTERY packs may create a risk of injury and fire.
- c. **When BATTERY pack is not in use, keep it away from other metal objects, like paper clips, coins, keys, nails, screws, or other small metal objects that can make a connection from one terminal to another.** Shorting the BATTERY terminals together may cause burns or a fire.
- d. **Under abusive conditions, liquid may be ejected from the BATTERY; avoid contact. If contact accidentally occurs, flush with water. If liquid contacts eyes, additionally seek medical help.** Liquid ejected from the BATTERY may cause irritation or burns.
- e. **Do not use a BATTERY pack or tool that is damaged or modified.** Damaged or modified batteries may show unpredictable behaviour resulting in fire, EXPLOSION, or risk of injury.
- f. **Do not expose a BATTERY pack or tool to fire or excessive temperature.** Exposure to fire or temperature above 130 °C (265 °F) may cause explosion.
- g. **Follow all charging instructions and do not charge the BATTERY pack or tool outside the temperature range specified in the instructions.** Charging improperly or at temperatures outside the specified range may damage the BATTERY and increase the risk of fire.

6. Service

- a. **Have your power tool serviced by a qualified repair person using only identical replacement parts.** This will ensure that the safety of the power tool is maintained.



b. **Never service damaged BATTERY packs.** Service of BATTERY packs should only be performed by the manufacturer or authorized service providers.

Battery Pack Safety Warnings

Only use the RAD Li-ion battery pack with the B-RAD Tool System. The use of other batteries with the B-RAD Tool System will cause damage to the tool.

The RAD Li-ion battery pack should only be charged on the RAD battery charger. If an incompatible charger is used, damage to the RAD battery will occur.

Keep the RAD Li-ion battery pack away from any metal objects. If the battery terminals are connected by a metal object, the battery will short and will cause damage to the battery and injury to the operator.

Do not expose the RAD Li-ion battery pack to wet conditions. This will cause damage to the RAD battery and increase the risk of electric shock.

Do not use faulty or deformed RAD batteries. Do not attempt to open the RAD battery. Do not short circuit the RAD battery. Failure to comply will cause damage to the RAD battery and injury to the operator.

If liquid is ejected from the RAD battery, avoid contact. If contact with skin occurs, immediately flush with water. If contact with eyes occurs, immediately flush with water and seek medical aid. Liquid from the RAD battery may cause irritation and/or burns.

RAD Li-ion battery packs cannot be disposed of with regular waste. Return RAD batteries to your RAD distributor.

1. GENERAL INFORMATION

1.1 System Components

The B-RAD Select Tool System is shipped in a storage case with the following parts:

- B-RAD Select Tool (Figure 1.1-1)
- Two RAD Li-ion battery packs (Figure 1.1-2)
- RAD battery charger (Figure 1.1-3)
- Standard reaction arm and snap ring (Figure 1.1-4)
- Calibration certificate
- User manual



Figure 1.1-1: B-RAD Select



Figure 1.1-2: RAD Li-Ion Battery Pack



Figure 1.1-3: RAD Battery Charger



Figure 1.1-4: Standard Reaction Arm



1.2 Specifications

1.2.1 Tool Model Specifications

The following tables outline the torque ranges, speed, and weight of the available B-RAD Select models:

Tool Model	Torque Range (Imperial)	Torque Range (Metric)	Speed	Weight (includes battery)
B-RAD Select 500 / 700-M	130-500 ft·lb	150-700 N·m	21.5 RPM	7.7 lb / 3.5 kg
B-RAD Select 1000 / 1400-M	200-1000 ft·lb	270-1400 N·m	10.5 RPM	7.7 lb / 3.5 kg
B-RAD Select 1000-2/1400-2-M	400-1000 ft·lb	540-1400 N·m	71.0 RPM	9.4 lb / 4.3 kg
B-RAD Select 1500 / 2000-M	300-1500 ft·lb	400-2000 N·m	6.00 RPM	8.9 lb / 4.0 kg
B-RAD Select 1500-2/2000-2-M			19.5 RPM	10.7 lb / 4.9 kg
B-RAD Select 3000 / 4000-M	600-3000 ft·lb	800-4000 N·m	3.00 RPM	13.3 lb / 6.0 kg
B-RAD Select 3000-2/4000-2-M			20.0 RPM	14.7 lb / 6.7 kg
B-RAD Select 5000 / 7000-M	1000-5000 ft·lb	1350-7000 N·m	2.10 RPM	19.3 lb / 8.8 kg

Table 1.2.1-1: Tool Model Torque Ranges and Weights

1.2.2 Battery Specifications

Ensure that all battery specifications are followed when using the B-RAD Tool System.

Battery Output	
Voltage	18 VDC
Current	30 A
Charge Time	60 minutes
Charger Voltage	
Input	115 or 230 VAC
Output	12 – 18 VDC
Charger Output Current	2.5 A

Table 1.2.2-1: Battery Specifications

1.2.3 Environmental Specifications



CAUTION!

Only operate the B-RAD Tool System if the following storage and operation conditions have been met.

It is recommended that the operator wears hearing protection.

WARNING!

The vibration emission during actual use of the power tool can differ from the declared total value depending on the ways in which the tool is used.

Identify safety measures to protect the operator that are based on an estimation of exposure in the actual conditions of use (taking account of all parts of the operating cycle such as the times when the tool is switched off and when it is running idle, in addition to the trigger time).

	All Models	
	C	F
Ambient Operating Temperature Range	0 – 35	32 – 95
Charging Temperature Range	0 – 50	32 – 122
Storage Temperature Range	-25 – 70	-13 – 158
Required Operating Conditions	Non-explosive atmosphere, dry location	
Humidity	10% to 90% non-condensing	
Shock	10G according to DIN IEC 68-2-6/29	
Vibration	Does not exceed 2.5 m/s ²	
Noise Emissions	90 ± 2 dB	

Table 1.2.3-1: Environmental Specifications

Note: The declared vibration total value has been measured in accordance with a standard test method. It may be used for comparing one tool with another and in a preliminary assessment of exposure.

1.2.4 Cycle of Operation

A cycle of operation or a tool cycle as used in this manual is defined as:

- 10 seconds on (forward or reverse)
- 10 seconds off

Note: The “on” here is defined as where torque is applied to the system.

Note: An actual torque cycle may vary from the general definition above.

2. TOOL SYSTEM

The following sections introduce the operation of the tool handle, LED display interface, RAD Li-ion battery pack, and RAD battery charger.

2.1 Tool Handle

The B-RAD Select (Figure 2.1-1) is activated with a trigger switch. The forward/reverse switch controls the direction of rotation. Torque values and tool information are displayed on the 4-digit LED display. Two buttons are used to enter the desired torque setting and view the menus. The RAD Li-ion battery pack is attached to the bottom of the tool handle.

1. Trigger switch – tool activation
2. Forward/reverse switch – controls direction of rotation: fully to the left is forward, fully to the right is reverse
3. LED display and **+**/**-** button module
4. RAD Li-ion battery pack – refer to Section 2.3 – RAD Li-Ion Battery Pack
5. Battery release button – refer to Section 2.3.1 – Insert/Remove the RAD Li-Ion Battery Pack



Figure 2.1-1: B-RAD Select and LED Display

2.1.1 Trigger Lock

The trigger lock is useful while transporting or storing the B-RAD. The trigger lock disables the use of the on/off trigger, therefore disabling the tool. It is suggested that while the B-RAD is not in use, the trigger lock should be enabled.

To enable the trigger lock:

Slide the forward/reverse switch to the centre position (neither fully to the right nor fully to the left).

Note: The on/off trigger cannot be pressed.

To disable the trigger lock:

Slide the forward/reverse switch to the forward position or the reverse position.

Note: The on/off trigger can be pressed.

2.2 LED Display Module



CAUTION!

The LED display module may be damaged by mechanical shock, electrostatic discharge, excessive force, moisture, or extreme temperatures. Avoid such conditions and gently wipe clean or let dry before use.

The LED display and the buttons are the interface for the B-RAD Select (See Figure 2.2-1). The LED display has 4 digits that display torque values and menu options. The **+** (plus, increase) and **-** (minus, decrease) buttons are used to modify numbers and navigate the various menus in the module. The interface is described in detail in Section 3 – Interface and Settings.

To turn on the LED display, attach the RAD Li-ion battery to the B-RAD Select handle and press the trigger switch momentarily. The display will light a small LED indicator near each button when a button is being pushed or held down.

The display will dim after 15 seconds of inactivity. Lightly pull the trigger or press a button to brighten the display. The display will turn off after 30 seconds. To turn it back on, lightly pull the trigger.



Figure 2.2-1: LED Display

2.3 RAD Li-Ion Battery Pack



CAUTION!

Only use the RAD Li-ion battery pack with the B-RAD Tool System. Using third-party batteries may damage the B-RAD Tool System.

Keep the RAD Li-ion battery pack away from any metal objects. If the battery terminals are connected by a metal object, the battery will short causing damage to the battery and injury to the operator.

The RAD Li-ion battery pack supplies power to the tool; for the B-RAD to perform best, ensure the RAD battery is fully charged and in good condition before use.

2.3.1 Insert/Remove the RAD Li-Ion Battery Pack

To insert the RAD battery:

1. Ensure the on/off trigger is in the off position (not depressed).
2. Align the RAD battery with the bottom of the tool handle.
3. Slide the RAD battery into place until it is fully seated.

Note: A click will confirm that the RAD battery is locked in place.

4. Check that the RAD battery is locked in place by trying to slide it out of place.

To remove the RAD battery:

1. Press and hold the “**Battery Release**” button.
2. Slide the RAD battery away from the tool handle.

Note: Once removed, do not insert the battery back into the tool for at least 10 seconds.

2.3.2 Check RAD Battery Charge

To check the RAD battery charge:

1. Press the “**Charge**” button on the RAD battery (Figure 2.3.2-1). The green bars will light up. If all the bars are illuminated, the battery is fully charged. If only one of the bars is illuminated, the RAD battery is discharged and needs charging (refer to Section 2.4.1 – Charging the RAD Li-Ion Battery Pack).
2. View the battery voltage on the B-RAD Select LED display from the Information Menu. See Section 3.2.2 – View the Battery Voltage.
3. When the battery charge gets too low, the LED display will flash a “Lo-b” message on the display.

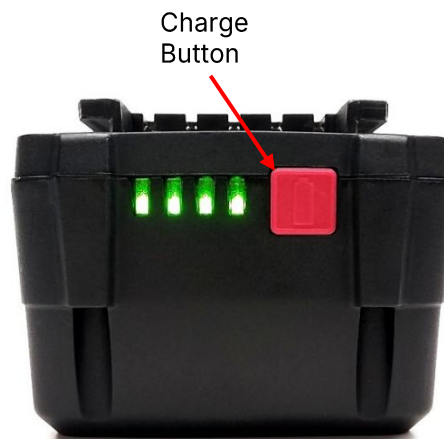

Figure 2.3.2-1: RAD Li-Ion Battery Pack

2.4 RAD Battery Charger



CAUTION!

The RAD Li-ion battery pack should only be charged on the RAD battery charger. If an incompatible charger is used, damage to the RAD Battery will occur.

The charging status display (Figure 2.4-1) indicates when the RAD Battery is charging, when the charge is complete, and if there is an error.

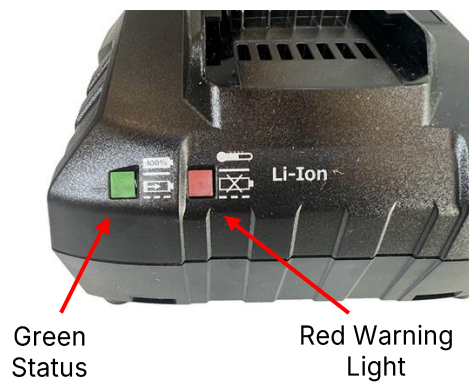

Figure 2.4-1: Charging Status Display

2.4.1 Charging the RAD Li-Ion Battery Pack

Note: The temperature range for charging is 0°C to 50°C (32 °F to 122 °F).

To charge the RAD battery:

1. Plug the RAD battery charger into the wall outlet. The red warning light will turn on for one second and then the green status light will turn on for one second.
2. Align the RAD battery with the RAD battery charger.
3. Slide the RAD battery into place. The green status light will flash while the RAD battery is charging.

When the RAD battery has been fully charged, the green status light will stop flashing and stay illuminated. Until the RAD battery is removed from the RAD charger, the charger will maintain the battery charge at maximum capacity.

To remove the RAD battery:

1. Slide the RAD battery away from the RAD charger.
2. Check that the RAD battery is fully charged (refer to Section 2.3.2 – Check RAD Battery Charge).

2.4.2 Charging Errors

The red warning light is on:

The RAD battery is not charging because its temperature is not within the required temperature range for charging. When the RAD battery's temperature changes to within the required range, the red warning light will turn off and charging will commence.

The red warning light is flashing:

The RAD battery may be placed incorrectly on the RAD battery charger. Remove the RAD battery and replace it correctly on the RAD battery charger. If the red warning light continues to flash, the RAD battery is defective; remove the RAD battery immediately.

If these problems continue, contact New World Technologies Inc. Technical Support (refer to Section 7.0 – Contact Us) or your RAD distributor.

3. INTERFACE AND SETTINGS

3.1 Changing Torque



CAUTION!

The B-RAD Select must be calibrated before use. If the LED display shows anything other than the Torque Select Screen, the Information Menu, or the Calibration Menu, contact New World Technologies Inc. Technical Support (refer to Section 7 – Contact Us) or your RAD distributor.

When the B-RAD Select is powered on, the LED display will start in Torque Select Mode (Figure 3.1-1).

Note: If the tool has just been calibrated, the LED display will show the tool's rated minimum torque.

When N·m (metric) units are used, the N·m indicator will light on the keypad. When ft·lb (imperial) units are used, the ft·lb indicator will light. (Refer to Section 3.2.1 – Change the Torque Units)

To change the torque value:

1. Press and hold a button until a digit starts blinking. The **-** button starts the left-most digit blinking. If the **-** button is pressed and held again, the selected digit moves to the right. The opposite happens with the **+** button.
2. Press the **+** or **-** button quickly to change the digits by one unit at a time. Other digits may be selected (see Step 1) to fine-tune the torque setting.
3. The selected torque value will be saved and ready after 5 seconds. Alternatively, press and hold the **-** button until the digit stops flashing. The display will blink, indicating that the value is saved. The torque value will be saved even when the battery is removed.

Table Mode:

The torque may be set in discrete levels from 1 to 50 over the calibrated range instead of using torque units (see Section 3.4 – Unlock Levels for the feature code). Setting 1 is the minimum calibrated torque, setting 50 is the maximum calibrated torque, and the points in between are evenly spaced over the tool's range. When Table Mode is entered, the previous calibrated torque value is converted into the corresponding table value.



Figure 3.1-1: Torque Mode Display

3.2 Information Menu

The Information Menu allows the operator to change torque units, view the battery voltage, change LED brightness, enter an unlock code, and view the program version. The menu items are described below.

To enter the Information Menu:

1. While in Torque Select Mode, hold the **+** button and momentarily press the **-** button.
2. To move to the next item, hold the **+** button and press the **-** button. To go to a previous menu item, hold the **-** button and press the **+** button.
3. To exit the menu, hold both buttons until the torque value is displayed. If an unlock code was entered, the locked or unlock mode will be displayed on the LEDs before the menu exits (see Section 3.4 – Unlock Levels for a list of codes).

3.2.1 Change the Torque Units

1. Press a button to toggle between *f* (foot-pounds) and *n* (newton-metres) as shown in Figures 3.2.1-1 and 3.2.1-2.
2. To exit the Unit Select Menu, press and hold both buttons.
3. The N·m indicator lights when N·m units are used (Figure 3.1.2-3), and the ft·lb indicator lights when ft·lb units are used (Figure 3.1.2-4).

Note: When the units are changed, the torque setting will be converted into the new units.



Figure 3.2.1-1: Units – ft·lb



Figure 3.2.1-2: Units – N·m



Figure 3.2.1-3: Ft·lb Display



Figure 3.2.1-4: N·m Display

3.2.2 View the Battery Voltage

1. Move to the next menu item: "batt." The battery voltage is shown (Figure 3.2.2-1 and Figure 3.2.2-2).
2. When the battery voltage gets too low, the message "Lo-b" will flash on any screen to warn that the battery needs charging.



Figure 3.2.2-1: Battery Menu



Figure 3.2.2-2: Actual Voltage

3.2.3 View Tool Temperature

1. Move to the next menu item: "Heat." Tool temperature is shown in Celsius (Figure 3.2.3-1 and Figure 3.2.3-2).
2. When the tool temperature is too low or too high, the messages "Cold" and "Hot", respectively, will flash on any screen and disable the tool from operating until it is at an acceptable temperature.

Note: If the temperature sensor is disconnected the message "tdi S" will be displayed.



Figure 3.2.3-1: Heat Menu



Figure 3.2.3-2: Temperature

3.2.4 Change the LED Brightness

1. Move to the next menu item: "Lite." The number of lines shown depict how bright the LED Display is (Figure 3.2.4-1 and Figure 3.2.4-2).
2. Use the + and - buttons to change the display brightness.



Figure 3.2.4-1: Lite Menu



Figure 3.2.4-2: LED Brightness

3.2.5 Enter a Lock or Unlock Code

1. Move to the next menu item: "Lock." The flashing line indicators on the screen keep track of the number of button presses used to enter a code (Figure 3.2.5-1 and Figure 3.2.5-2).
2. Enter a code using the + and - buttons. The desired code will depend on which features are needed. See Section 3.4 – Unlock Levels for more information.
3. Navigate forward or press and hold both buttons to accept the code and close the menu. The new unlock level will scroll across the screen.



Figure 3.2.5-1: Lock Menu



Figure 3.2.5-2: Code Entry -
Button Presses

3.2.6 View Program Version

1. Move to the next menu item, labelled "Prog." The program version number will scroll across the screen as shown in Figure 3.2.6-1.



Figure 3.2.6-1: Program Menu

3.3 Tool Menu

The Tool Menu displays tool model information and is the menu used to calibrate the tool. When in Locked or Basic levels, only the tool information may be viewed. When in Easy Calibration access level, the calibration points may be modified. The menu items are described in more detail in Section 5 – Calibration.

To enter the Tool Menu:

1. While in Torque Select Mode, hold the **-** button and momentarily press the **+** button.
2. To move to the next item, hold the **+** button and press the **-** button. To go to a previous menu item, hold the **-** button and press the **+** button.
3. To exit the menu, hold both buttons until the display flashes and the torque value is displayed. Any changes made in the Calibration Menu will be saved.

To view tool information:

1. The first menu item is "Tool." This displays the gearbox number and model in the calibrated units.
2. Move to the next menu item. The tool serial number is displayed.
3. The next two items display the minimum and maximum torque values.
4. If in Calibration Mode, the next options define the minimum and maximum calibration limits and the calibration points. Changing these values will affect the output torque. See Section 5 – Calibration.

3.4 Unlock Levels

The B-RAD Select has several access levels which change the operation of the tool and the interface. The access levels are described below. The codes may be entered using the Lock Code Menu (see Section 3.2.5 – Enter a Lock or Unlock Code). After the code is entered and the menu is closed, the level is displayed on the LED display. If the wrong code is entered, no message will be displayed after exiting.



Access Level	Displayed Name	How To Use the Code	Description	Code
Torque Mode <i>(Default Mode)</i>	Basic	Used to switch to Torque Mode.	<i>(This is the Default mode)</i> Basic Display Mode enables setting the torque value. Displays torque in physical units (ft·lb or N·m) as calibrated.	
Table Mode	Select	Used to switch to Table Mode.	Select Display Mode enables selecting 50 evenly spaced torque levels over the calibrated range.	
Locked	Lock	Code is used to lock and unlock current mode.	Locking the tool freezes the selected Display Mode. Information Menu: Unit Select, Battery level, Heat, LED brightness, Code entry, and Program version available. Tool Menu: disabled	
Easy-Calibration	Calibr	Used to switch to Easy-Cal.	Change calibration values. See Section 5 – Calibration.	Contact Us or your RAD distributor

Table 3.4-1: Access Levels, Features, and Codes

4. GENERAL OPERATING INSTRUCTIONS

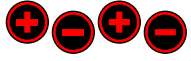

CAUTION!

Only qualified personnel with training in the safe operation of torque tooling and the B-RAD Tool System should operate this tool. Refer to the Important Safety Notice for more information.

The B-RAD operates in torque cycles. The torque cycle passes when the actual torque reaches the target torque, and the cycle fails if it is interrupted before the actual torque reaches the target torque.

This section instructs the operator in the use of the reaction arm needed for B-RAD operation and how to conduct a torque cycle.

4.1 Reaction Arm



WARNING!

Always keep body parts clear of the reaction arm when the B-RAD Tool System is in use. Serious injury could occur.

CAUTION!

Ensure that the reaction arm has a solid contact point before operating the B-RAD Tool System.

Improper reaction will void warranty and can cause premature tool failure.

Please contact New World Technologies Inc. or your local RAD authorized distributor for information on custom reaction arms.

Installing the Reaction Arm

Slide the reaction arm onto the spline or serpentine fitting and secure the snap ring to hold the reaction arm in place. Couple the socket and square drive together with a dowel pin and secure with a locking ring.

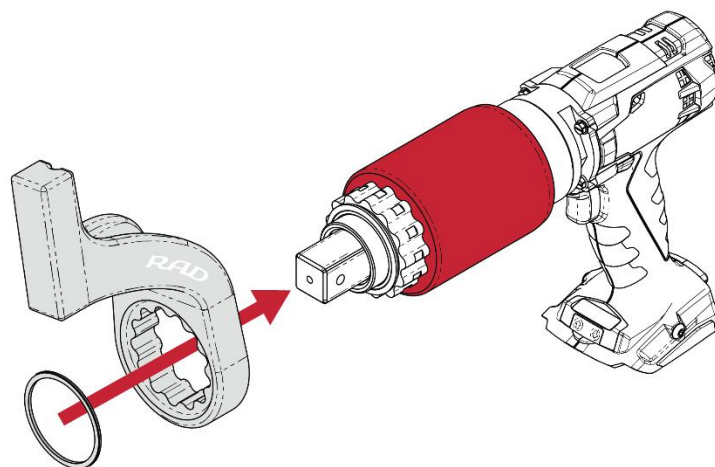

Reaction Points

Make sure that the reaction arm is in contact with a solid reaction point before operating the tool.

When the tool is in operation, the reaction arm rotates in the opposite direction to the output square drive and must be allowed to rest squarely against a solid object or surface adjacent to the bolt to be tightened.

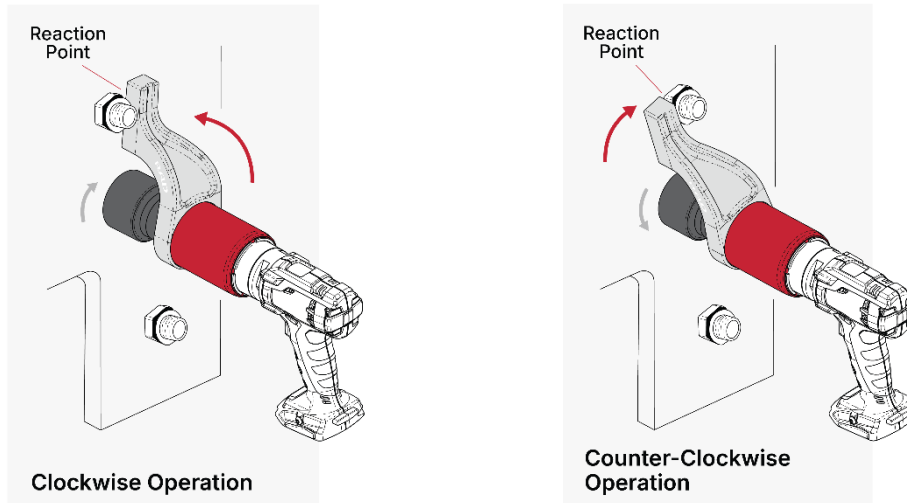

Personal Safety



CAUTION!

Keep hands clear of the reaction arm and joint when the tool is in operation.

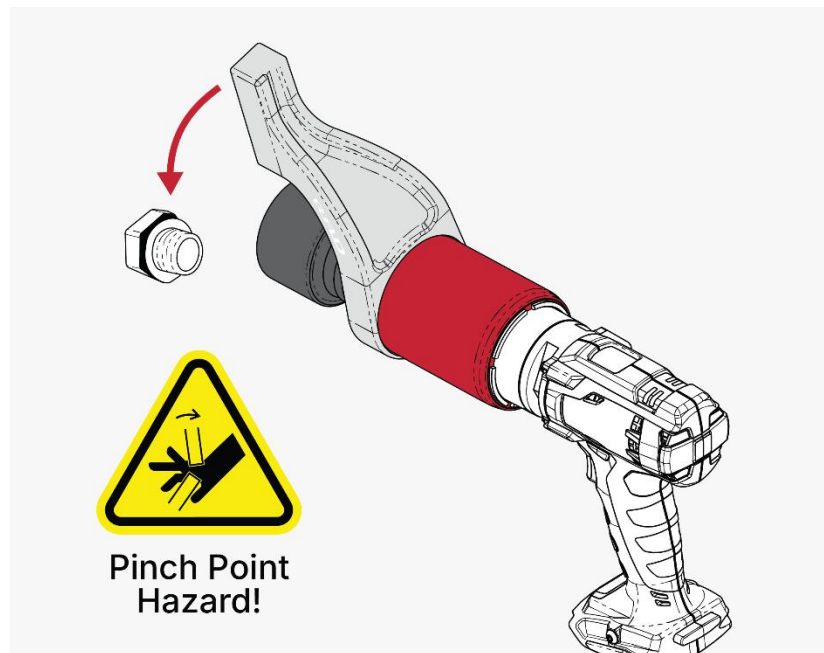

Reaction Arm Height

For proper tool function, ensure that the height of the socket is even with the height of the reaction arm.

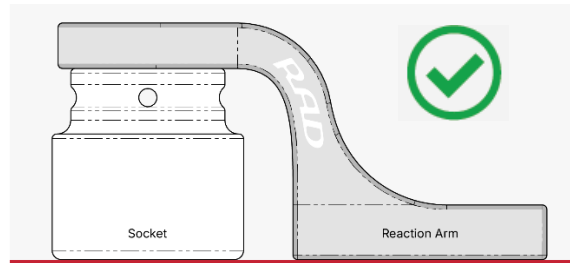

Correct: The socket and reaction arm are aligned

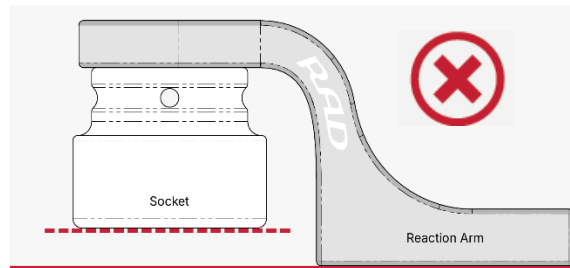
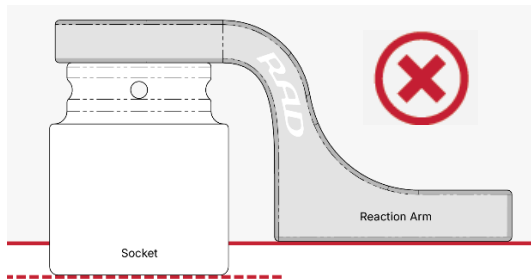

Incorrect: The leg of the reaction arm is too short in the left image and too long in the right image

Reaction Arm Foot

Make sure the foot of the reaction arm is positioned directly against the reaction point to ensure correct function

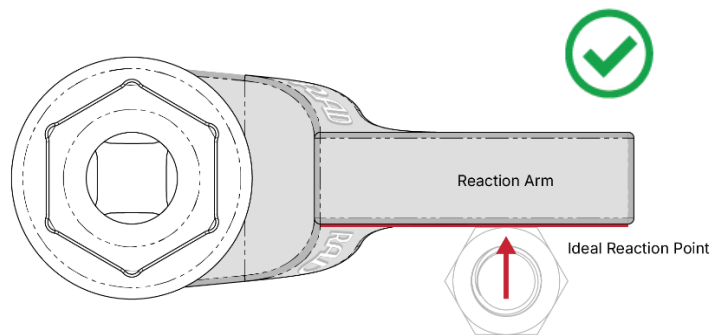

Reaction Point

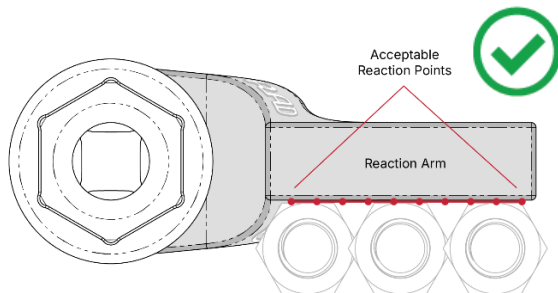

Good reaction point:
Reacting perpendicular to the reaction arm

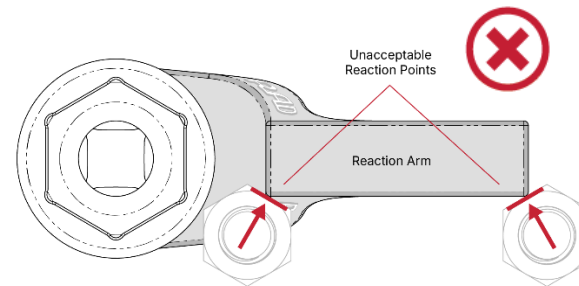

Bad reaction point:
Reacting at the angle towards the heel or the toe of the reaction arm

4.2 Torque Operation

To operate the tool in a torque cycle:

1. Ensure the tool is in Torque Select Mode (example in Figure 4.2-1. Also see Section 3.1 – Changing Torque).
2. Ensure the LED display is showing the correct units (see Section 3.2.1 – Change the Torque Units).
3. Change the torque value as desired (see Section 3.1 – Changing Torque). Allow the display to flash after changing the torque, indicating that the torque value is saved and set.
4. The B-RAD Select is ready to torque at the displayed setting. Place the B-RAD on the joint system.
5. Ensure the forward/reverse switch is in the forward position.
6. Press and release on/off trigger to ensure tool is awake.
7. Press and hold the on/off trigger.

Note: To stop the torque cycle at any time, release the on/off trigger.

8. When the B-RAD reaches the selected torque, the tool will stop turning. Release the on/off trigger.



Figure 4.2-1: Torque Select Mode

5. CALIBRATION



CAUTION!

Only qualified personnel with training in the safe operation of torque tooling and the B-RAD Select Tool System should operate this tool. Improper use of the calibration function will result in tool damage.

Do not calibrate at target torques that result in exceeding the B-RAD Select Tool System's torque range. Severe tool damage will occur.

This function allows the operator to access the calibration values for the B-RAD. These values should only be modified by a qualified calibration technician and using a calibration stand.

5.1 Calibration Menu Navigation

The functions available in Calibration depend on which Unlock level the B-RAD Select is in. See Section 3.4 – Unlock Levels for details.

To enter the Calibration Menu:

1. While in Torque Select Mode, hold the **-** button and press the **+** button. Make sure to release the **+** button first. The Tool Menu will appear (Figure 5.1-1).

To change numeric values within each menu:

1. Press and hold either the **+** or the **-** button until a digit flashes. Repeat until the desired digit is flashing, then use the **+** or **-** button to change the number.
2. To exit the Edit Mode, press and hold either button. The value will be saved and the cursor will stop flashing.

To advance the menu items:

1. Hold the **+** button and press the **-** button to advance to the next menu item (illustrated in Figure 5.1-2).
2. Hold the **-** button and press the **+** button to return to the previous menu item.
3. To view the title of a menu item, press the **-** button for 3 seconds. The title is displayed for as long as the button is held.

Note: Showing the menu title will also reset the menu value to the previously saved value if the value was changed.

4. Any changed values will be saved when the menu is in Advanced. A modified value is indicated by the two dots on the LED display blinking quickly. When the value is saved, the LED dots blink more slowly.



Figure 5.1-1: Tool (Calibration) Menu



Figure 5.1-2: Menu Advance Function

5.2 Table of Calibration Menus

The order and function of the menus in Calibration Mode are outlined in Table 5.2 below.

Note: Only CPhi, CPLo, and the CAL points are available after the first cycle through the menu. The first 4 options become available when the calibration menu is opened again.

Menu Title	Description of Function
Safe	2-Hand safety switch – Sets the 2-Hand Safety Mode.
Tool	Gearbox model – View the current tool model. The models are shown in Table 5.2.2 below.
Ser	Tool serial number. Can only be changed by factory.
Lo	Minimum torque limit – Set up to 50% higher than default. Can only be changed by factory.
Hi	Maximum torque limit – Set down to 50% lower than rated maximum. Can only be changed by factory.
CPhi	Calibration point high – Sets the maximum tool output for calibration. The value may range between 10 and 990.
CPLo	Calibration point low – Sets the minimum tool output for calibration. The value may range between 10 and 990.
CAL1, CAL2, ... CAL6	Tool calibration points – Calibrates output torque at six evenly spaced points over the output range.

Table 5.2-1: Calibration Menu Titles and Functions

5.3 Table of Tool Models

The first menu in Calibration Mode is the Gearbox Select Menu. Table 5.3 shows which gearbox setting in the menu corresponds to the desired tool model.

Gearbox Designator	Tool Model
G00	Default: 10 – 990
G01	40 – 200 ft·lb
G02	50 – 270 N·m
G03	70 – 350 ft·lb
G04	100 – 470 N·m
G05	130 – 500 ft·lb
G06	150 – 700 N·m
G07	200 – 1000 ft·lb
G08	270 – 1400 N·m
G09	300 – 1500 ft·lb
G10	400 – 2000 N·m
G11	600 – 3000 ft·lb
G12	800 – 4000 N·m
G13	1000 – 5150 ft·lb
G14	1350 – 7000 N·m
G15*	400 – 1000 ft·lb
G16*	540 – 1400 N·m

Table 5.3-1: Calibration Mode Gearbox Values

Note: G15 and G16 are associated with the 2-Speed models of their gearbox size.

5.4 Two-Hand Safety Modes



Mode	Displayed	Operation
Off – No Two-Hand		<p>Disables Two-Hand operation. Use this setting for tools without Two-Hand switch hardware.</p> <p>Note: It is recommended to calibrate in this mode. Do not forget to change to the correct setting after verification.</p>
Single Cycle – Press to start		<p>The Two-Hand switch must be pressed to start a torque cycle. Afterwards the safety switch can be released and the tool will continue to run.</p> <p>Note: Pressing the safety switch again will stop the tool.</p> <ul style="list-style-type: none"> - Torques 1 time: trigger must be pulled first, then Two-Hand switch is pressed. - Two-Hand switch can be released after tool starts. - Must release Two-Hand switch after cycle to before starting new cycle.
Operate – Press and hold		<p>The Two-Hand switch must be pressed to start a torque cycle. It must be held down for the duration of the cycle.</p> <p>Note: This option replicates the current hardware functionality.</p> <ul style="list-style-type: none"> - Torques if trigger and Two-Hand switch is pressed. - Can release either and press it again to continue cycle. - Two-hand switch can be held down after cycle and new cycle can be started.
Single Cycle Operate – Press and hold then release		<p>The Two-Hand switch must be pressed to start a torque cycle. It must be held down for the duration of the cycle. The switch must be released between cycles.</p> <p>Note: This mode is intended to prevent the operator from disabling the safety switch.</p> <ul style="list-style-type: none"> - Torques 1 time: Two-Hand switch is pressed and held first, then the trigger is pulled. - Must hold Two-Hand switch after tool starts. - Must release Two-Hand switch after cycle to before starting new cycle.

Table 5.4-1: Two-Hand Safety Modes Description



5.5 Calibration Procedure

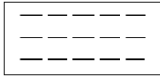
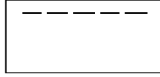
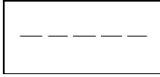

CAUTION!

DO NOT operate the B-RAD Select Tool System beyond 50 units above the rated maximum torque. Over-torquing the tool will cause severe tool damage.

To calibrate the B-RAD Select:

1. See Section 3.4 – Unlock Levels to ensure the correct access level is enabled. Some settings in the Calibration Menu are restricted to higher levels.
2. Install a fresh battery into the B-RAD Select.
3. Enter Calibration Mode by holding the  button then pressing the  button.
4. Select the correct tool model using Table 5.3 above. If the tool has previously been calibrated, this value cannot be changed.
Note: The units of the tool model are indicated by the green LED.
5. Navigate to the next selection in the Calibration Menu labelled "SER." The serial number is displayed.
6. The next two menu items show the lower and upper torque limits of the tool's torque range.
7. Before any calibration points are set, it is recommended that the tool is warmed up near the tool's maximum setting (approximately 10 pulls around the maximum torque will warm up the tool). Navigate forward to "CPhi."
8. Set the level to a value lower than 800 (the default is 750). Take a pull on the calibration stand.
9. If the output torque is lower than the rated maximum of the tool, gradually increase the tool percentage until the torque readings nearly match the maximum torque of the tool. Adjust the value to achieve approximately 50 units above maximum torque.
10. Advance to the "CPLo" menu.
11. Take a pull at the default setting.
12. Gradually increase or decrease the percentage setting until the tool pulls approximately 50 units below the tool's minimum torque. For example, a 1000 ft·lb tool has a minimum of 200 ft·lb, so the torque to be reached would be 150 ft·lb. See Table 5.3 for a full list of B-RAD Tool ranges.
13. Navigate to the next menu in Calibration Mode. The display will show "CAL 1."
14. Take one pull at "CAL 1" and record the measured torque value.
15. Enter the torque value (See Section 5.1 – Calibration Menu Navigation).
16. Navigate to the next Calibration menu "CAL 2." Take a pull and record the measured value, as before.
17. Enter the torque value.
18. Repeat Steps 17-18 for the remaining CAL points.
19. Finally, exit Calibration Mode by pressing and holding both buttons until the display flashes and Torque Mode is displayed. All calibration data will be saved.

If the units are changed using the Information Menu (see Section 3.2.1 – Change the Torque Units), the calibration values will be converted in the calibration menu.

6. TROUBLESHOOTING

**IMPORTANT!**

Disassembling or attempting repair will void warranty.

If breakdown, malfunction, or error occurs, contact New World Technologies Inc. Technical Support (refer to Section 7 – Contact Us).

The LED display may exhibit abnormal behaviour depending on operating conditions, frequency of use, or excessive wear on the display module.

The display module is designed to withstand normal use over the lifetime of the B-RAD Select Tool System; however, as a sensitive electronic device it is susceptible to damage caused by shock, moisture, or excessive force.

7. CONTACT Us

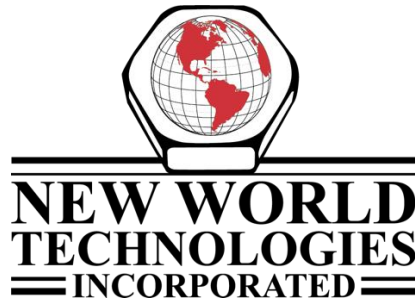

TF: 1-800-983-0044 **F:** 604-852-0269
W: www.radtorque.com **E:** info@radtorque.com

Technical Support

P: 1-800-983-0044 (EXT. 227)
E: service@radtorque.com

New World Technologies Inc.

100-30722 Marshall Road
Abbotsford, BC V2T 0H9
Canada



The Bluetooth® word mark and logos are registered trademarks of Bluetooth SIG, Inc. and any use of such marks by New World Technologies Inc. is under license. Other trademarks and trade names are those of their respective owners.

B-RAD SELECT LIMITED WARRANTY

NEW TOOL WARRANTY

Any new tool branded with the RAD name and purchased from New World Technologies Inc., or through one of its authorized distributors or agents, is warranted to the original purchaser against defects in materials and workmanship for a period of one (1) year from the date of original calibration. Electric drive components such as electric motors, switches, and batteries etc., are covered for a period of six (6) months from the date of original calibration. Under the terms of this warranty, New World Technologies Inc., at its option and F.O.B. either its factory or an authorized service center, will replace or repair for the original purchaser, free of charge, any part or parts, found upon examination by New World Technologies Inc., to be defective in material or workmanship or both. If any product or part is replaced or repaired under the terms of this warranty, that product or part will carry the remainder of the warranty from the date of original calibration.

REPAIRED TOOL WARRANTY

Once a tool is beyond its new tool warranty, New World Technologies Inc., for a period of three (3) months from the date of repair, will replace or repair for the original purchaser, free of charge, any part or parts, found upon examination by New World Technologies Inc., to be defective in material or workmanship or both. If any product or part is replaced or repaired under the terms and conditions of this warranty, that product or part will carry the remainder of the warranty from the date of original repair.

To qualify for the above mentioned warranties, written notice to New World Technologies Inc. must be given immediately upon discovery of such defect, at which time New World Technologies Inc. will issue an authorization to return the tool. The defective item must promptly be returned to New World Technologies Inc. all freight charges prepaid. When returning a tool, the reaction arms being used with the tool must also be returned.

NEW WORLD TECHNOLOGIES INC. | T: 1.800.983.0044 | E: INFO@RADTORQUE.COM

EXCLUSIONS FROM WARRANTY

Tools or accessories found by New World Technologies Inc.'s sole judgment to have been altered, damaged, misused, abused, badly worn due to excessive utilization, lost, or improperly maintained will NOT be covered under the terms of this warranty.

Tools returned without the reaction arms will not be covered under the terms of this warranty.

Consumable parts and accessories (such as extensions, reaction blanks/arms) are not covered under this warranty.

Tools that have been relabeled without prior written consent of New World Technologies Inc. will not be covered under this warranty.

Equipment and accessories not manufactured by New World Technologies Inc. (measuring equipment, etc.) are warranted only to the extent of the original manufacturer's warranty.

**There is no other express warranty. Implied warranties, including those of merchantability and fitness for a particular purpose are limited to one year from date of calibration and to the extent permitted by law. Liability for consequential damages under any and all warranties are excluded to the extent exclusion is permitted by law.*

LIGHTER FASTER STRONGER SAFER



ABOUT NEW WORLD TECHNOLOGIES INC.

New World Technologies is a leading Canadian manufacturer of pneumatic, battery powered, and electronic pistol grip torque wrenches. Our advanced products have proven to be successful all over the world in such industries as oil and gas, petrochemical, mining, aerospace, and manufacturing. We continue to invest in and employ the latest technology to achieve the highest level of Innovation, quality, and performance - which has resulted in multiple patents for our products.



NEW WORLD TECHNOLOGIES INC

#100 - 30722 MARSHALL RD | ABBOTSFORD, BC V2T 0H9 | CANADA
604.852.0405 | INFO@RADTORQUE.COM | RADTORQUE.COM